



**PFS
Test
Report**

PFS TEST REPORT #09-147A

**LMT MERCER GROUP, INC – ADA RAIL SYSTEM
IBC 2006 AND IRC 2006 TESTING
FOR
LMT MERCER GROUP INC
LAWRENCEVILLE, NEW JERSEY**



By:
PFS Corporation
1507 Matt Pass
Cottage Grove, WI 53527



PFS Laboratory Services

Testing • Research • Consulting • Model Code Qualifications
Quality Assurance • Design Calculations • Sampling • Witnessing

ENGINEERED WOOD PRODUCTS

MDF panels, I-Joists, Rim-board, LVL, Trusses

WOOD-PLASTIC COMPOSITE LUMBER and GUARDRAIL SYSTEMS

Deck boards, Structural Elements, Guards, and Handrails

BUILDING STRUCTURAL COMPONENTS

Load Bearing Performance

STRUCTURAL INSULATED PANELS

Structural Performance and Adhesive Qualification

STRUCTURAL and CONSTRUCTION ADHESIVES

Exterior Wet-Use, Building Materials Product Use, Sub-floor, and General Purpose

ROOF COVERINGS and EXTERIOR SIDINGS

All types

FASTENERS and CONNECTIONS

Nails, Screws, Staples, Bolts, Connector Plates, Joist Hangers

CORPORATE HEADQUARTERS and LABORATORY

1507 Matt Pass
Cottage Grove, WI 53527
Tel: (608) 839-1013
Fax: (608) 839-1014
Michael J. Slifka, PE
mslifka@pfscorporation.com
James A. Rothman, PE
jrothman@pfscorporation.com

MIDWEST REGION

1507 Matt Pass
Cottage Grove, WI 53527
Tel: (608) 839-1013
Fax: (608) 839-1014
Ronald H. Reindl, AIA
rreindl@pfscorporation.com

SOUTH CENTRAL REGION

2520 K Avenue, Suite 700-735
Plano, TX 75074
Tel: (972) 424-2740
Fax: (608) 839-3995
Jeremy Hopland
jerhopland@pfscorporation.com

NORTHEAST REGION

2877 Skatetown Road
Bloomsburg, PA 17815
Tel: (570) 784-8396
Fax: (570) 784-5961
Richard L. Wenner, PE
rwenner@pfscorporation.com

WESTERN REGION

3637 Motor Avenue, Suite 380
Los Angeles, CA 90034
Tel: (310) 559-7287
Fax: (310) 559-1368
J. Robert Nelson, PE
rnelson@pfscorporation.com

SOUTHEAST REGION

10105 Ethridge Court
Raleigh, NC 27615
Tel: (919) 845-8450
Fax: (919) 845-8454
Larry A. Beineke, PE, Ph.D.
lbeineke@pfscorporation.com



PFS Corporation

Assurance you can build on[®]

An Employee-Owned Company

Headquarters

1507 Matt Pass
Cottage Grove, WI 53527

Phone: 608.839.1013
Fax: 608.839.1014

Website

www.pfscorporation.com

Michael J. Slifka, PE

President
mslifka@pfscorporation.com

James A. Rothman, PE

Executive Vice President
Senior Vice President, QC
jrothman@pfscorporation.com

Regional Offices

Northeast

Bloomsburg, PA
570.784.8396

Southcentral

Plano, TX
972.424.2740

Western

Los Angeles, CA
310.559.7287

Midwest

Cottage Grove, WI
608.839.1013

Southeast

Raleigh, NC
919.845.8450

Sales Office

Mentone, AL
256.634.4071

**PFS TEST REPORT #09-147A
LMT MERCER GROUP, INC – ADA RAIL SYSTEM
IBC 2006 AND IRC 2006 TESTING
FOR
LMT MERCER GROUP INC
LAWRENCEVILLE, NEW JERSEY**

GENERAL

The PFS Corporation, Cottage Grove, Wisconsin, performed client requested testing services for LMT Mercer Group Incorporated, Lawrenceville, New Jersey. A PFS representative obtained the test materials by performing sampling services at the client’s facility. Testing is for “LMT Mercer Group, Inc – ADA” hand rail compliance evaluation with IBC 2006 and IRC 2006 hand rail requirements. The handrail test specimens were received in good order at PFS on October 23, 2009.

TEST SPECIMENS

Testing was performed on submitted handrail design as per client drawing “revised 10/9/09” LMT Mercer Group drawing “Hand Rail Test Setup” dated 9/24/09 (copy attached.).

The handrail test specimen consists of rail composed of an aluminum round tube with dimensions of 78-in-long, 1.29-in.-O.D.-by- 0.11-in.-wall round tube with 0.10-in.-wall vinyl cover. The rail is attached with powder coated aluminum brackets. The brackets attach to the rail with 2 #12 x 1-in.-long SS FH PH screws (predrilled using 13/64 drill bit). The mounting brackets are spaced at 72-in.-on-centers. A 3-in. overhang (measured from mounting bracket center to end of rail) occurs at each end. The rail system overall diameter was 1-1/2-in.

The handrail test assembly was mounted to a simulated wall consisting of a 4-by-6 treated Southern Pine dimension lumber with 3/8-in.-diamter steel through bolts. One bolt for each mounting bracket.

A new handrail and mounting brackets were used for each of the four tests.

TESTS AND REQUIREMENTS

IBC 2006 Requirements

Sec. 1607.1 Handrail assemblies and guard shall be designed to resist a load pf 50 plf applied in any direction at the top and to transfer this load through the supports to the structure.

1. Load applied vertical downward load .
2. Load applied horizontal away from supports.

Sec. 1607.7.1.1 Handrail assemblies and guards shall be able to resist a single concentrated load of 200 pounds applied in any direction at any point along the top.

1. Load applied vertical downward directly above one support
2. Load applied vertical downward at center between supports



IRC 2006 Requirement (Cont.)

Table R301.5 Guardrails and Handrails

A minimum concentrated load of 200 lbf applied in any direction at any point along the top.

TEST SET-UP

The tests were performed with a new set up for each of the four tests. The IBC concentrated load requirement is essentially the same as the IRC requirement and only performed once.

The load was applied with a hydraulic cylinder and test fixture apparatus. The test force was measured with an electronic load cell positioned between the test specimen and hydraulic cylinder. The load was gradually applied until the test requirement force magnitude was obtained.

The concentrated load to mounting bracket used an approximately 1-in.-wide section of wood-plastic composite with concave area to match the handrail curvature. Concentrated load to mid-span was applied to rail with steel foot. See Photos No. 1 and No. 2

The 50 plf load test was applied with reactions points located at 1/3 of the test span. Note - 50 plf for 6-ft.-span is maximum of 300 lbf. See Photo No. 3

TEST RESULTS

The LMT Mercer Group – ADA Hand Rail system, test results met the IRC 2006 and IBC 2006 hand rail test requirements.

Test Witnessed and
Report Reviewed by:



Deepak Shrestha
Lab Technical Manager

Report Prepared by:



James P. Van Schoyck
Laboratory Administrator

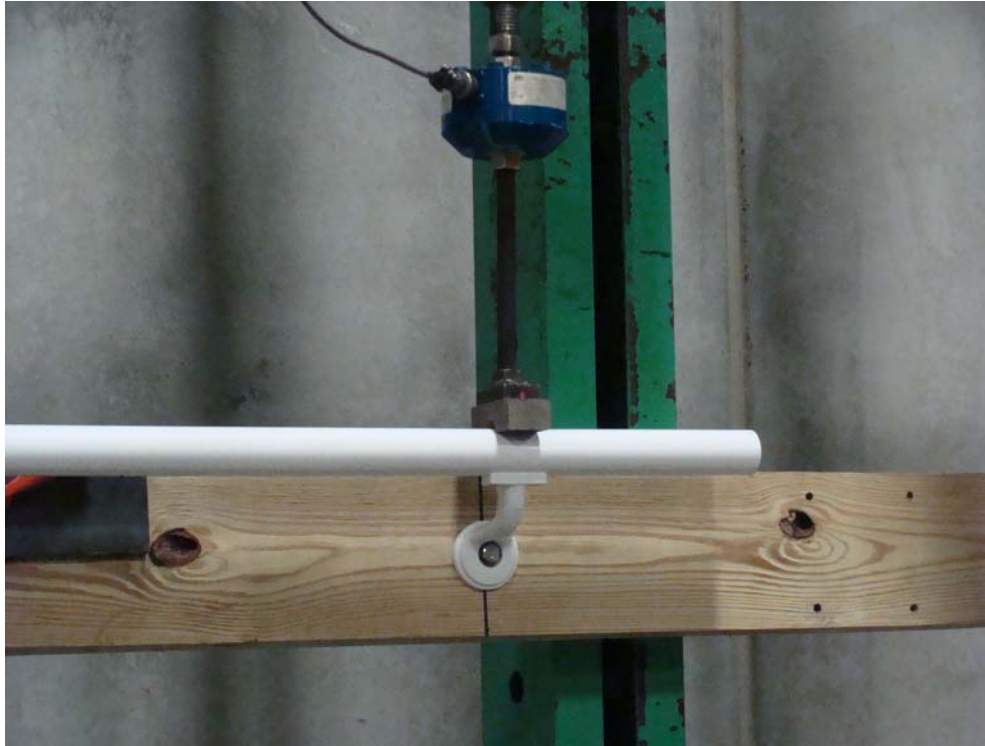

PHOTO 1: Concentrated Load at Support (photo taken at 200 lbf load).

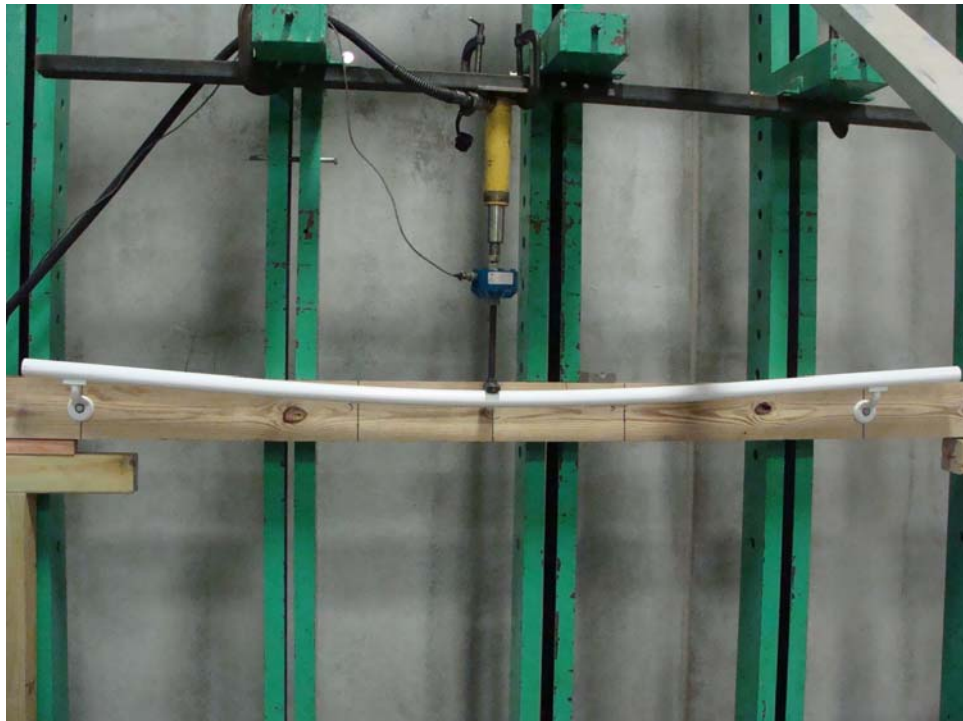

PHOTO 2: Concentrated Load at Mid-Span (photo taken at 200 lbf load)



PHOTO 3: 50 plf Load Applied – Horizontal (photo taken at 300 lbf)



PHOTO 4: 50 plf Load – Vertical (photo of set-up, no load applied)

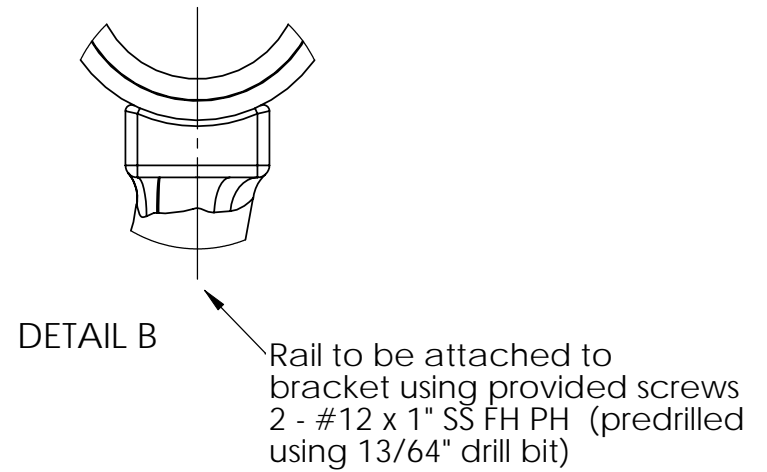
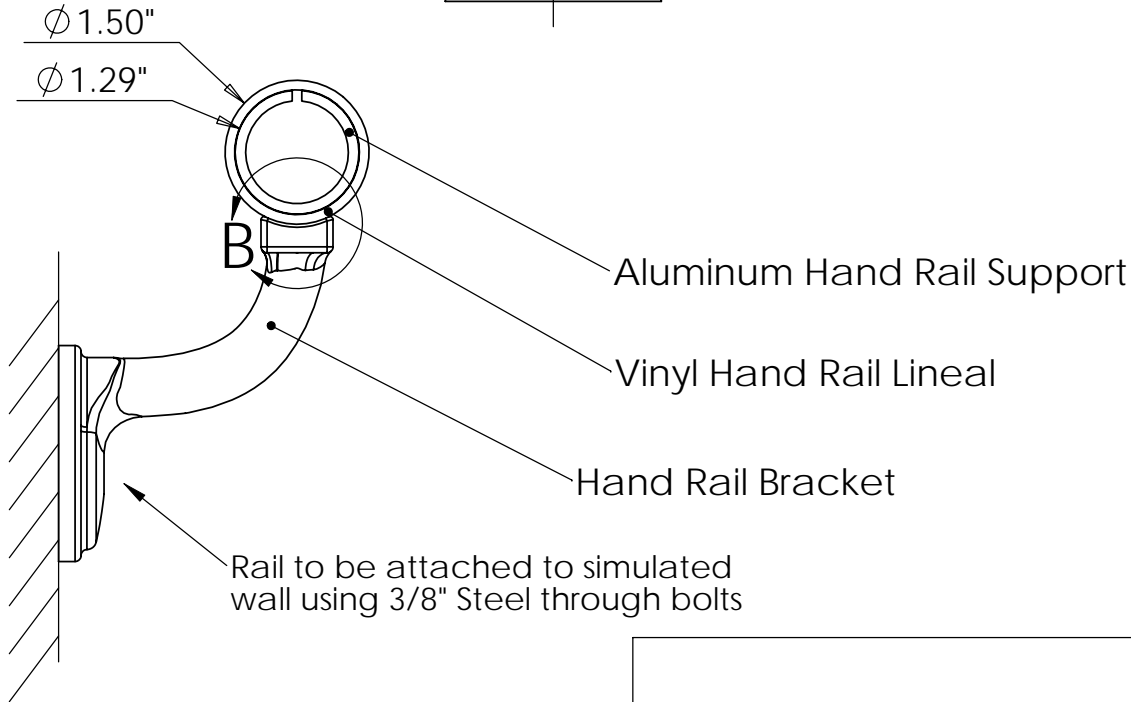
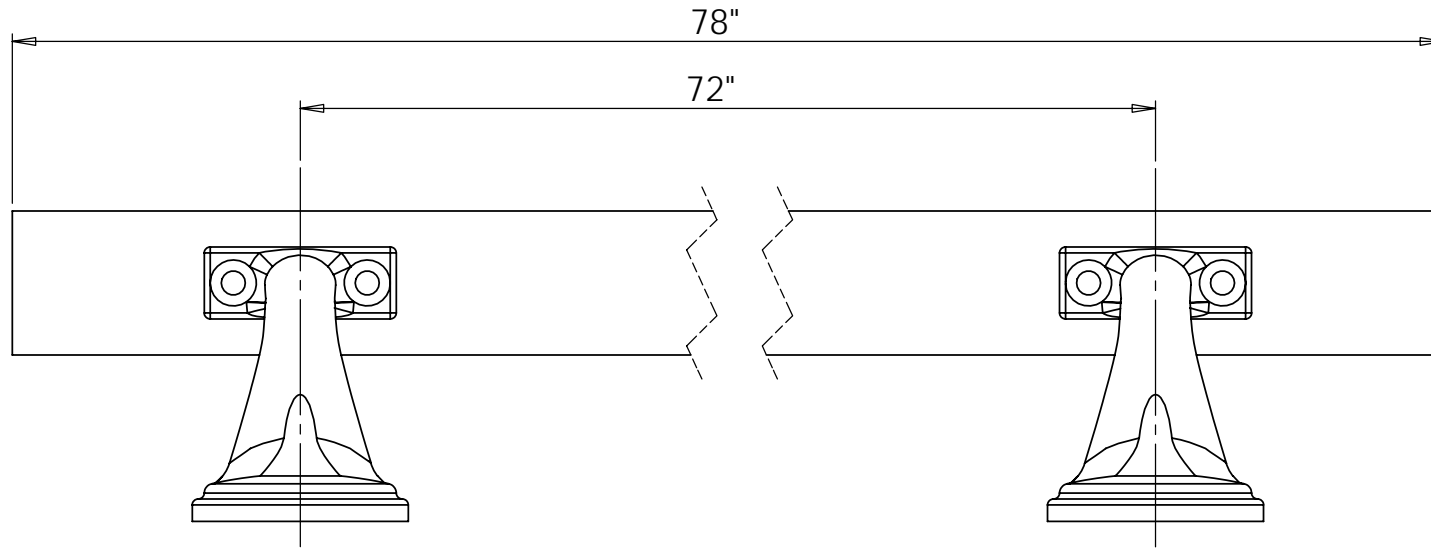

REV.	DESCRIPTION	DATE	BY

Hand Rail Test Set-Up			
SIZE A	DO NOT SCALE DRAWING	Part #	REV A
SCALE NONE	DRAWN BY JMW	DATE 9/24/09	SHEET 1 OF 1