



DEPARTMENT OF REGULATORY AND ECONOMIC RESOURCES (RER)  
BOARD AND CODE ADMINISTRATION DIVISION

MIAMI-DADE COUNTY  
PRODUCT CONTROL SECTION  
11805 SW 26 Street, Room 208  
Miami, Florida 33175-2474  
T (786) 315-2590 F (786) 315-2599

[www.miamidade.gov/economy](http://www.miamidade.gov/economy)

**NOTICE OF ACCEPTANCE (NOA)**

**Westech Building Products, Inc.**  
4751 Hwy 62 East  
Mount Vernon, IN 47620

**SCOPE:**

This NOA is being issued under the applicable rules and regulations governing the use of construction materials. The documentation submitted has been reviewed and accepted by Miami-Dade County RER- Product Control Section to be used in Miami Dade County and other areas where allowed by the Authority Having Jurisdiction (AHJ).

This NOA shall not be valid after the expiration date stated below. The Miami-Dade County Product Control Section (In Miami Dade County) and/or the AHJ (in areas other than Miami Dade County) reserve the right to have this product or material tested for quality assurance purposes. If this product or material fails to perform in the accepted manner, the manufacturer will incur the expense of such testing and the AHJ may immediately revoke, modify, or suspend the use of such product or material within their jurisdiction. RER reserves the right to revoke this acceptance, if it is determined by Miami-Dade County Product Control Section that this product or material fails to meet the requirements of the applicable building code.

This product is approved as described herein, and has been designed to comply with the High Velocity Hurricane Zone of the Florida Building Code.

**DESCRIPTION: Extruded PVC Vinyl Fencing Systems**

**APPROVAL DOCUMENT:** Drawing No. 10-02, titled "PVC Privacy Fence systems", sheets 1 through 9 of 9, prepared by Al-Farooq Corporation, dated April 09, 2010, last revision #C dated August 18, 2015, signed and sealed by Javad Ahmad, P.E., bearing the Miami-Dade County Product Control Revision stamp with the Notice of Acceptance number and the expiration date by the Miami-Dade County Product Control Section.

**MISSILE IMPACT RATING: None**

**LABELING:** Each fence section shall bear a permanent label with the manufacturer's name or logo, city, state, and the following statement: "Miami-Dade County Product Control Approved", unless otherwise noted herein.

**RENEWAL** of this NOA shall be considered after a renewal application has been filed and there has been no change in the applicable building code negatively affecting the performance of this product.

**TERMINATION** of this NOA will occur after the expiration date or if there has been a revision or change in the materials, use, and/or manufacture of the product or process. Misuse of this NOA as an endorsement of any product, for sales, advertising or any other purposes shall automatically terminate this NOA. Failure to comply with any section of this NOA shall be cause for termination and removal of NOA.

**ADVERTISEMENT:** The NOA number preceded by the words Miami-Dade County, Florida, and followed by the expiration date may be displayed in advertising literature. If any portion of the NOA is displayed, then it shall be done in its entirety.

**INSPECTION:** A copy of this entire NOA shall be provided to the user by the manufacturer or its distributors and shall be available for inspection at the job site at the request of the Building Official.

This NOA **revises and renews** NOA #12-0612.22 and consists of this page 1, evidence submitted pages E-1 & E-2 as well as approval document mentioned above.

The submitted documentation was reviewed by **Helmy A. Makar, P.E., M.S.**



*Helmy A. Makar*  
06/16/2016

NOA No. 15-1013.08  
Expiration Date: 10/06/2020  
Approval Date: 06/16/2016  
Page 1

**Westech Building Products, Inc.**

**NOTICE OF ACCEPTANCE: EVIDENCE SUBMITTED**

**1. EVIDENCE SUBMITTED UNDER PREVIOUS APPROVAL # 10-0512.03**

**A. DRAWINGS**

1. *Drawing No. 10-02, titled " PVC Privacy Fence systems ", sheets 1 through 9 of 9, prepared by Al-Farooq Corporation, dated April 09, 2010, last revision #A dated September 02, 2010, signed and sealed by Javad Ahmad, P.E.*

**B. TESTS**

1. *Test report on Uniform Static Air Pressure Test, prepared by Architectural Testing, Report # 91017.02-119-18, dated September 17, 2009, signed and sealed by Joseph A. Reed, P.E.*

**C. CALCULATIONS**

1. *Calculations titled PVC Privacy fence System (4 ft & 6 ft tall), by Al-Farooq Corporation, dated April 30, 2010, sheets L1, D-1, CR-1, WL-1 to WL-7, TR-1 to TR-4, & C-1 to C-34, signed and sealed by Javad Ahmad, P.E., on May 04, 2010.*

**D. MATERIAL CERTIFICATIONS**

1. *Extruded Profile (Phantom) Specification sheets.*

**E. STATEMENTS**

1. *Letter regarding the compliance with Florida Building Code 2007 and the lack of financial interest, prepared by Al-Farooq Corporation, dated April 30, 2010, signed and sealed by Javad Ahmad, P.E., on May 04, 2010.*

**2. EVIDENCE SUBMITTED UNDER PREVIOUS APPROVAL # 12-0612.22**

**A. DRAWINGS**

1. *Drawing No. 10-02, titled " PVC Privacy Fence systems ", sheets 1 through 9 of 9, prepared by Al-Farooq Corporation, dated April 09, 2010, last revision #B dated June 06, 2012, signed and sealed by Javad Ahmad, P.E.*

**B. TESTS**

1. *None.*

**C. CALCULATIONS**

1. *None.*

**D. QUALITY ASSURANCE**

1. *By Miami-Dade County Department of Regulatory and Economic Resources.*

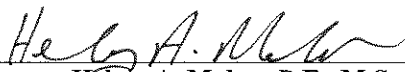
  
\_\_\_\_\_  
**Helmy A. Makar, P.E., M.S.**  
**Product Control Section Supervisor**  
**NOA No. 15-1013.08**  
**Expiration Date: 10/06/2020**  
**Approval Date: 06/16/2016**

**Westech Building Products, Inc.**

**NOTICE OF ACCEPTANCE: EVIDENCE SUBMITTED**

**E. MATERIAL CERTIFICATIONS**

1. *None.*

**F. STATEMENTS**

1. *Letter regarding the compliance with Florida Building Code 2010 and the lack of financial interest, prepared by Al-Farooq Corporation, dated June 06, 2012, signed and sealed by Javad Ahmad, P.E.*

**3. NEW EVIDENCE SUBMITTED**

**A. DRAWINGS**

1. *Drawing No. 10-02, titled " PVC Privacy Fence systems ", sheets 1 through 9 of 9, prepared by Al-Farooq Corporation, dated April 09, 2010, last revision #C dated August 18, 2015, signed and sealed by Javad Ahmad, P.E.*

**B. TESTS**

1. *None.*

**C. CALCULATIONS**

1. *None.*

**D. QUALITY ASSURANCE**

1. *By Miami-Dade County Department of Regulatory and Economic Resources.*

**E. MATERIAL CERTIFICATIONS**

1. *None.*

**F. STATEMENTS**

1. *Letter of compliance with Florida Building Code 2014 Edition and the lack of financial interest, prepared by Al-Farooq Corporation, dated September 24, 2015, signed and sealed by Javad Ahmad, P.E.*

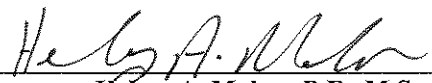
  
\_\_\_\_\_  
**Helmy A. Makar, P.E., M.S.**  
**Product Control Section Supervisor**  
**NOA No. 15-1013.08**  
**Expiration Date: 10/06/2020**  
**Approval Date: 06/16/2016**

**PVC PRIVACY FENCE SYSTEMS**

THIS PRODUCT HAS BEEN DESIGNED AND TESTED TO COMPLY WITH THE REQUIREMENTS OF THE FLORIDA BUILDING CODE 2014 EDITION INCLUDING HIGH VELOCITY HURRICANE ZONE (HVHZ).

INSTALLATION OR LOADING CONDITIONS OTHER THAN THOSE SHOWN IN THESE DETAILS ARE NOT PART OF THIS APPROVAL.

ALL CONCRETE SHALL HAVE A 28 DAY COMPRESSIVE STRENGTH OF 3000 PSI.

FENCE SYSTEMS COVERED UNDER THIS APPROVAL SHALL BE MANUFACTURED FROM RIGID PVC HOMOPOLYMER, SIC 3084 PROFILES.

FENCES SHALL BE INSTALLED AS PER MANUF'S INSTALLATION INSTRUCTIONS.

**PRODUCT MARKING**

A LABEL SHALL BE AFFIXED ON EACH FENCE WITH THE FOLLOWING STATEMENT.

WESTECH BUILDING PRODUCTS, INC., VERNON, IN.  
'MIAMI-DADE COUNTY PRODUCT CONTROL APPROVED'

FENCE SYSTEMS ARE DESIGNED FOR 75 MPH WIND SPEED OR 115 MPH 3 SECOND GUSTS IN COMPLIANCE WITH THE FLORIDA BUILDING CODE.

Engr: JAVAD AHMAD  
CIVIL  
FLA. PE # 70592  
C.A.N. 3538

SEP 30 2015

PRODUCT REVISED  
as complying with the Florida  
Building Code  
Acceptance No 15-1013-08  
Expiration Date 10/06/2020  
By *[Signature]*  
Miami Dade Product Control

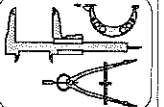
<b>AL-FAROOQ CORPORATION</b> ENGINEERS & PRODUCT DEVELOPMENT 1235 S.W. 87 AVE MIAMI, FLORIDA 33174 TEL (305) 264-8100 FAX (305) 262-6978 FENCES \ 10-02WBP																	
																	
PVC PRIVACY FENCE SYSTEMS <b>WESTECH BUILDING PRODUCTS, INC.</b> 7451 HIGHWAY 62 EAST MOUNT VERNON, INDIANA. 47620 TEL. (812) 985-3628 FAX. (812) 985-2925																	
date: 04-09-10 scale: - dr. by: HAMID chk. by:	<table border="1"> <thead> <tr> <th>no</th> <th>date</th> <th>description</th> <th>by</th> </tr> </thead> <tbody> <tr> <td>A</td> <td>09.02.10</td> <td>REV. PER BCCO COMMENTS</td> <td></td> </tr> <tr> <td>B</td> <td>06.06.12</td> <td>UPDATED TO 2010 FBC</td> <td></td> </tr> <tr> <td>C</td> <td>08.18.15</td> <td>UPDATED TO 2014 FBC</td> <td></td> </tr> </tbody> </table>	no	date	description	by	A	09.02.10	REV. PER BCCO COMMENTS		B	06.06.12	UPDATED TO 2010 FBC		C	08.18.15	UPDATED TO 2014 FBC	
no	date	description	by														
A	09.02.10	REV. PER BCCO COMMENTS															
B	06.06.12	UPDATED TO 2010 FBC															
C	08.18.15	UPDATED TO 2014 FBC															
drawing no. <b>10-02</b>																	
sheet 1 of 9																	

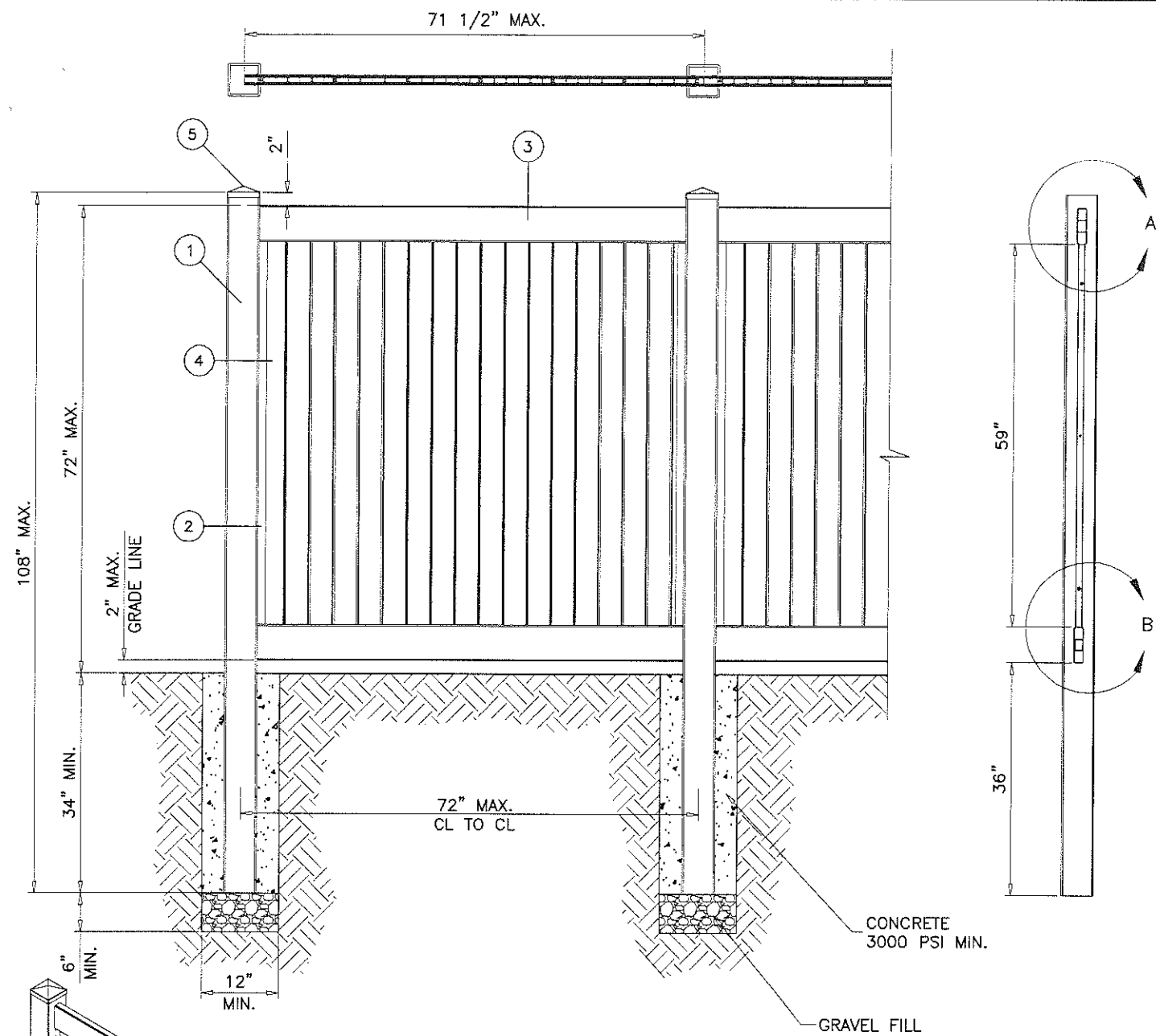

TYPICAL ELEVATION  
1/2" = 1'-0"

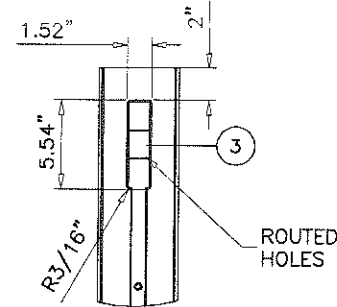
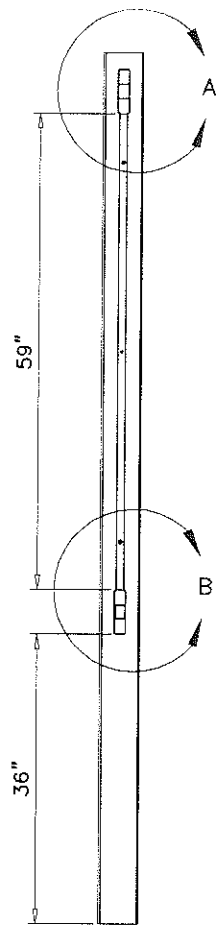

DETAIL 'A'  
1" = 1'-0"

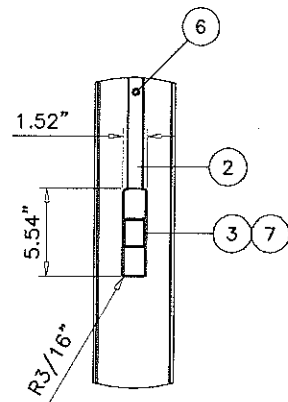

DETAIL 'B'  
1" = 1'-0"

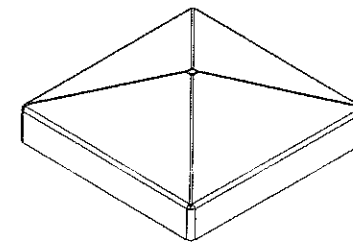

5" HORSE CAP

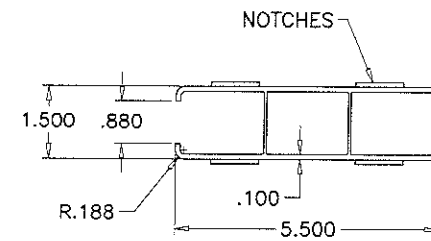

RAIL

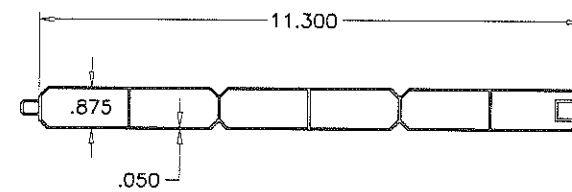

INTERLOCK

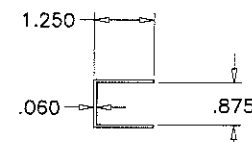

CHANNEL

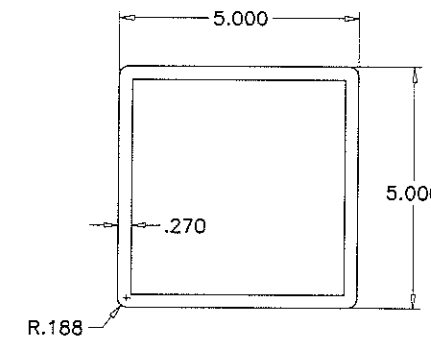

POST

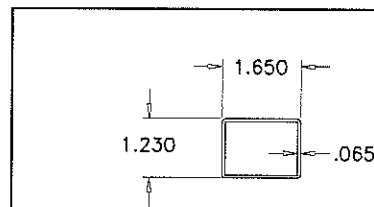

BOTTOM RAIL STIFFENER (6063-T5)

11.3" T&G PRIVACY FENCE

ITEM NO.	PART DESCRIPTION	LENGTH IN.
1	5" X 5" POST	108
2	7/8" U CHANNEL	58-7/8
3	1-1/2" X 5-1/2" RAIL	71-1/2
4	7/8" X 11.3" T&G	62-1/4
5	5" HORSE CAP	N/A
6	1/2" FASTENERS	N/A
7	BOTTOM RAIL STIFFENER	71-1/2

ALUMINUM STIFFENER AT BOTTOM RAIL ADDED TO REDUCE DOWNWARD DEFLECTION

Engr: JAVAD AHMAD  
CIVIL  
FLA. PE # 70592  
C.A.N. 3538

PRODUCT REVISED  
as complying with the Florida:  
Building Code  
Acceptance No. 15-1013.08  
Expiration Date 10/06/2020  
By: *[Signature]*  
Miami Data Product Control

SEP 30 2015

AL-FAROOQ CORPORATION  
ENGINEERS & PRODUCT DEVELOPMENT  
1235 S.W. 87 AVE  
MIAMI, FLORIDA 33174  
TEL. (305) 264-8100 FAX. (305) 262-6978  
FENCES 10-02WRP

PVC PRIVACY FENCE SYSTEMS  
WESTECH BUILDING PRODUCTS, INC.  
7451 HIGHWAY 62 EAST  
MOUNT VERNON, INDIANA. 47620  
TEL. (812) 985-3628 FAX. (812) 985-2925

no	date	description
A	09.02.10	REV. PER BCCD COMMENTS
B	06.06.12	NO CHANGE THIS SHEET
C	08.18.15	UPDATED TO 2014 FBC

date: 04-09-10  
scale: 1/4" = 1"  
dr. by: HAMID  
chk. by:

drawing no.  
10-02  
sheet 2 of 9

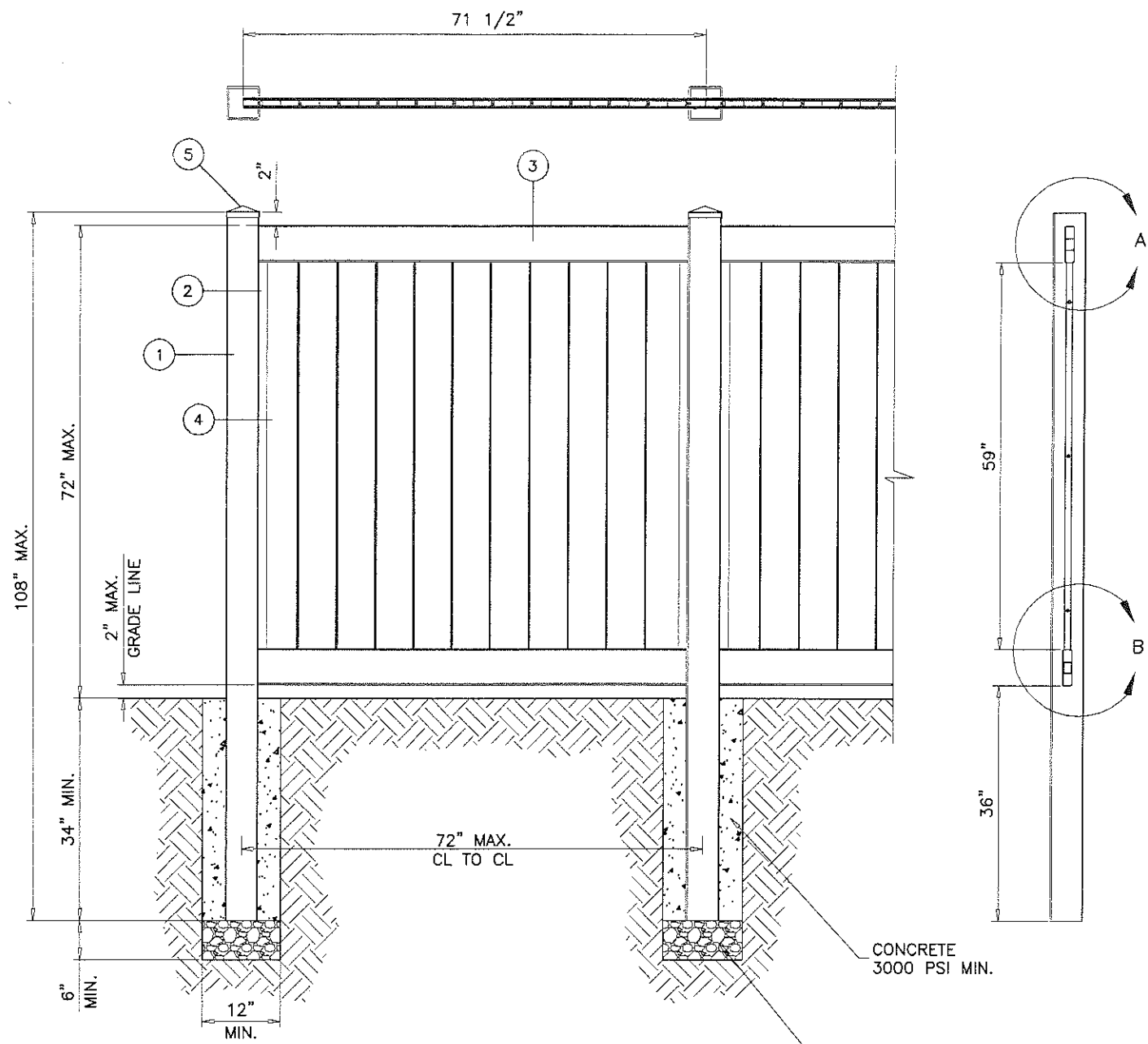

TYPICAL ELEVATION  
1/2" = 1'-0"

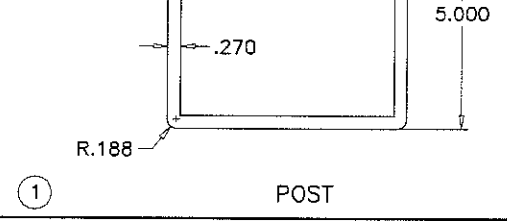
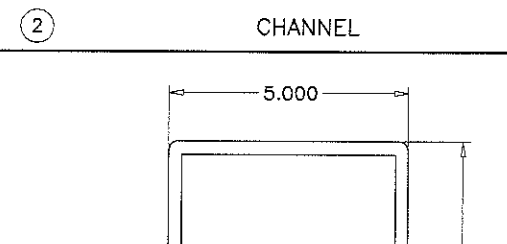
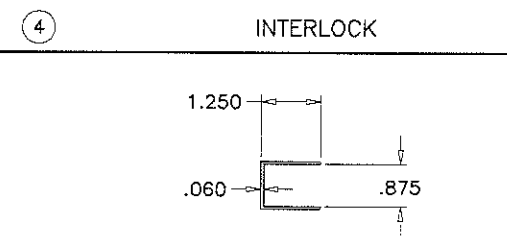
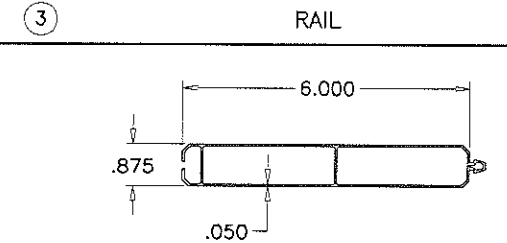
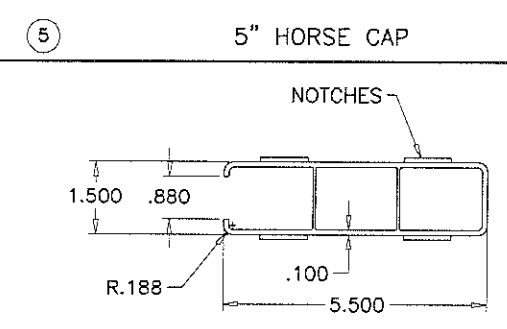
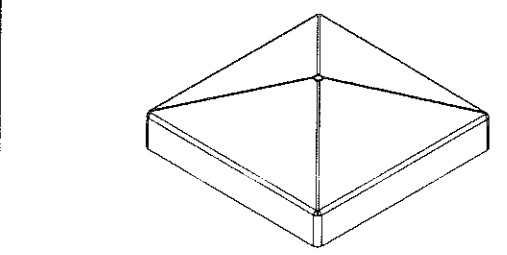
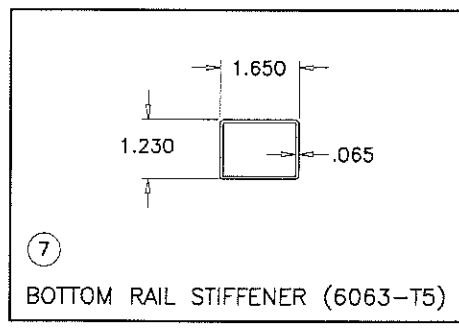
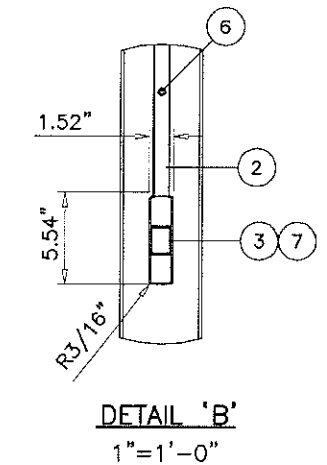
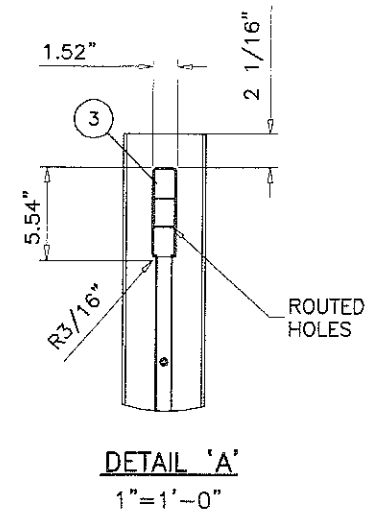

6" T&G PRIVACY FENCE

ITEM NO.	PART DESCRIPTION	LENGTH IN.
1	5" X 5" POST	108
2	7/8" U CHANNEL	58-7/8
3	1-1/2" X 5-1/2" RAIL	71-1/2
4	7/8" X 6" T&G	62-1/4
5	5" HORSE CAP	N/A
6	1/2" FASTENERS	N/A
7	BOTTOM RAIL STIFFENER	71-1/2

ALUMINUM STIFFENER AT BOTTOM RAIL ADDED TO REDUCE DOWNWARD DEFLECTION

Engr: JAVAD AHMAD  
CMI  
FLA. PE # 10592  
C.A.N. 3538  
SEP 30 2015

PRODUCT REVISED  
as complying with the Florida  
Building Code  
Acceptance No 15-1013.08  
Expiration Date 10/06/2020  
By: *[Signature]*  
Miami Dept Product Control

**AL-FAROOQ CORPORATION**  
ENGINEERS & PRODUCT DEVELOPMENT  
1235 S.W. 87 AVE  
MIAMI, FLORIDA 33174  
TEL (305) 264-8100 FAX (305) 262-6978  
FENCES\10-02WB/P

PVC PRIVACY FENCE SYSTEMS  
**WESTECH BUILDING PRODUCTS, INC.**  
7451 HIGHWAY 62 EAST  
MOUNT VERNON, INDIANA. 47620  
TEL. (812) 985-3628 FAX. (812) 985-2925

no	date	description
A	09.02.10	REV. PER BCCO COMMENTS
B	06.06.12	NO CHANGE THIS SHEET
C	08.18.15	UPDATED TO 2014 FBC

date: 04-09-10  
scale: 1/4" = 1"  
dr. by: HAMID  
chk. by:

drawing no.  
**10-02**  
sheet 3 of 9

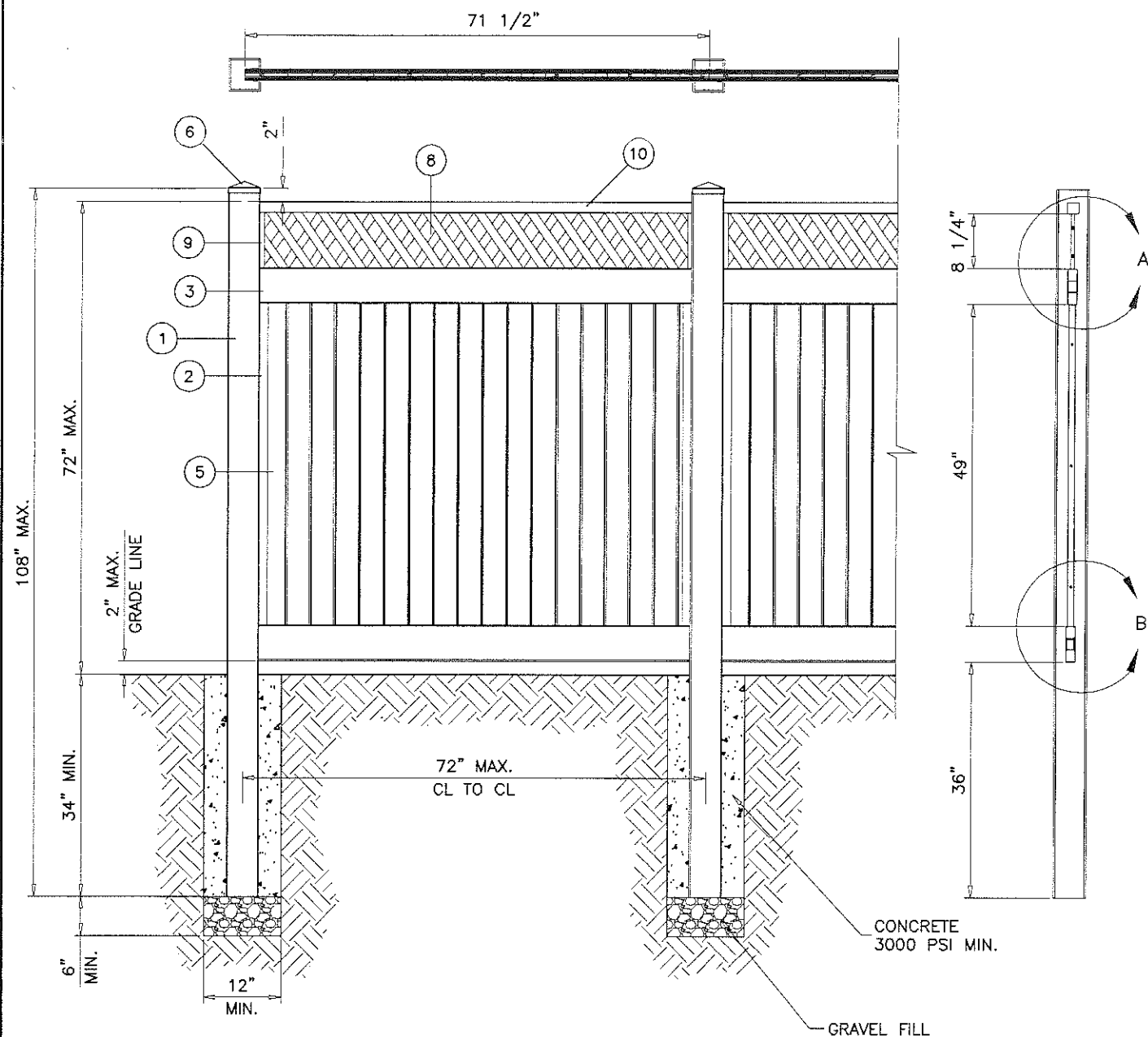

TYPICAL ELEVATION  
1/2" = 1'-0"

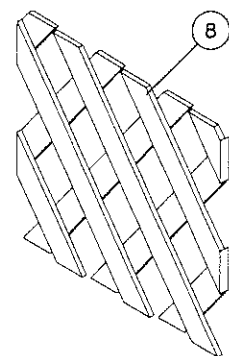
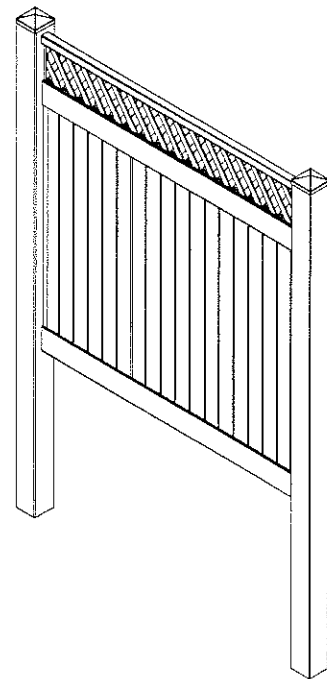

LATTICE ACCENT 11.3" PRIVACY FENCE

ITEM NO.	PART DESCRIPTION	LENGTH IN.
1	5" X 5" POST	108
2	7/8" U CHANNEL	48-7/8
3	1-1/2" X 5-1/2" RAIL	71-1/2
5	7/8" X 11.3" T&G	52-1/4
6	5" HORSE CAP	N/A
8	1/2" LATTICE	N/A
9	5/8" U CHANNEL	8-1/4
10	1-3/4" X 1-3/4" RAIL	71-1/2
11	1/2" FASTENERS	N/A
12	BOTTOM RAIL STIFFENER	71-1/2

ALUMINUM STIFFENER AT BOTTOM RAIL ADDED TO REDUCE DOWNWARD DEFLECTION

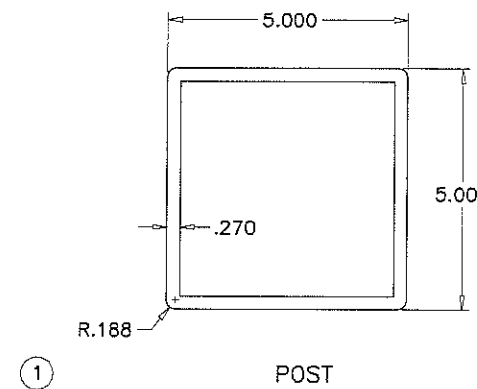
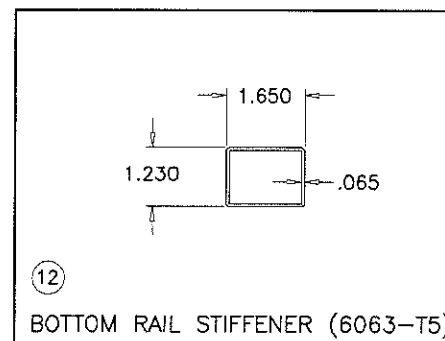
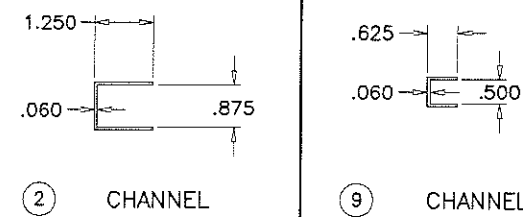
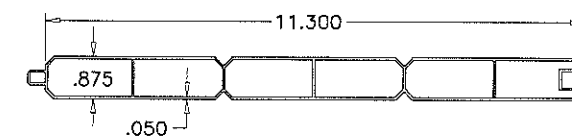
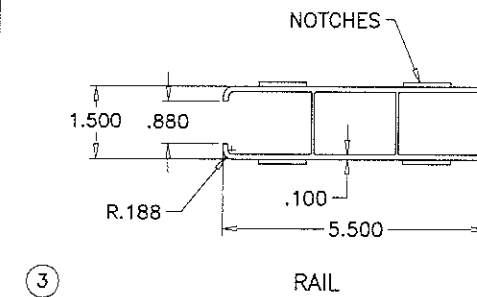
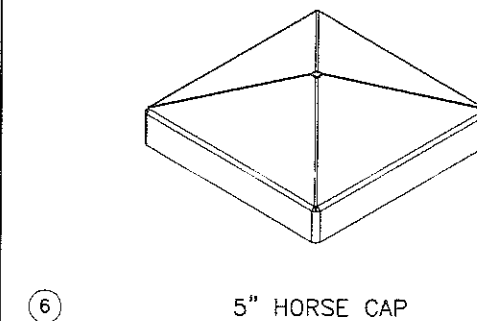
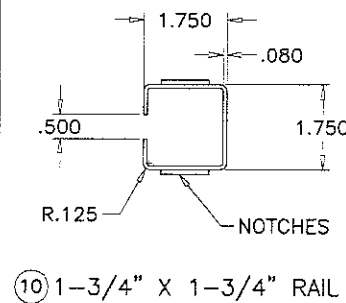
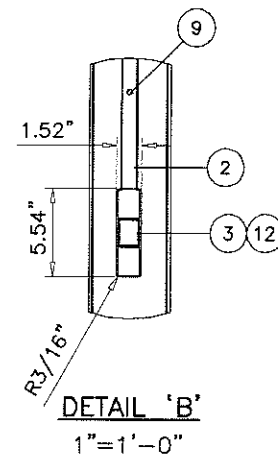
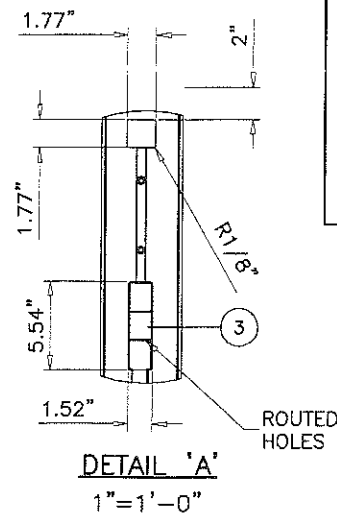

Engr: JAVAD AHMAD  
CML  
FLA. PE # 70592  
C.A.N. 3538  
SEP 10 2015

PRODUCT REVISED  
as complying with the Florida  
Building Code  
Acceptance No 15-1013.08  
Expiration Date 10/06/2020  
By: *[Signature]*  
Miami Design Product Control

AL-FAROOQ CORPORATION  
ENGINEERS & PRODUCT DEVELOPMENT  
1235 S.W. 87 AVE  
MIAMI, FLORIDA 33174  
TEL (305) 264-8100 FAX (305) 262-6978  
FENCES 10-02WB

PVC PRIVACY FENCE SYSTEMS  
WESTECH BUILDING PRODUCTS, INC.  
7451 HIGHWAY 62 EAST  
MOUNT VERNON, INDIANA. 47620  
TEL. (812) 985-3628 FAX. (812) 985-2925

no	date	description
A	09.02.10	REV. PER BCCO COMMENTS
B	06.06.12	NO CHANGE THIS SHEET
C	08.16.15	UPDATED TO 2014 FBC

date: 04-09-10  
scale: 1/4" = 1'  
dr. by: HAMID  
chk. by:  
drawing no.  
10-02  
sheet 4 of 9

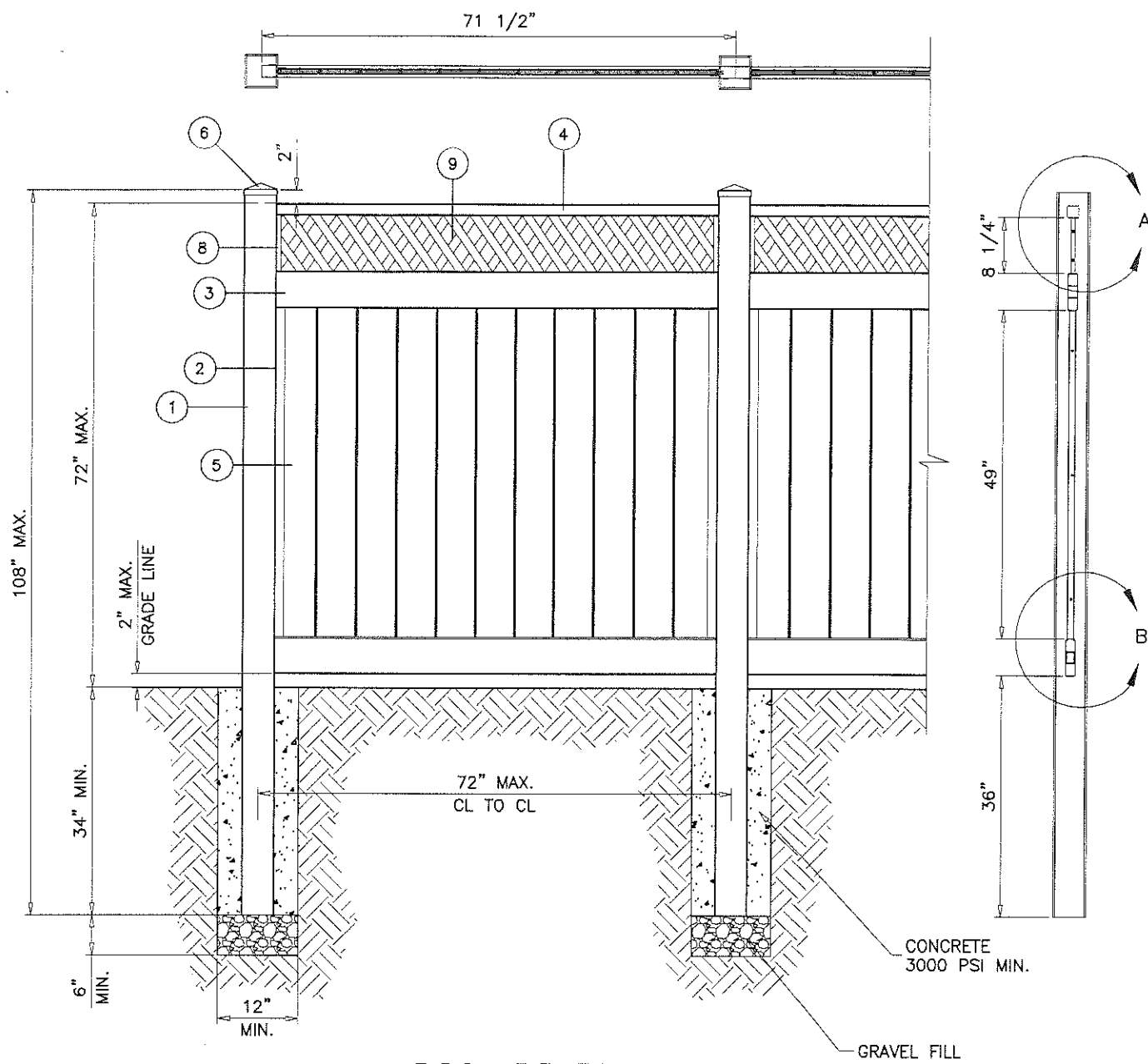

TYPICAL ELEVATION  
1/2" = 1'-0"

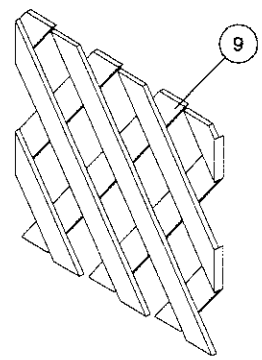
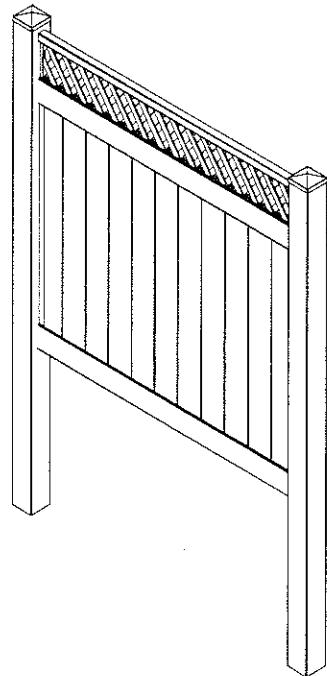

LATTICE ACCENT 6" PRIVACY FENCE

ITEM NO.	PART DESCRIPTION	LENGTH IN.
1	5" X 5" POST	108
2	7/8" U CHANNEL	48-7/8
3	1-1/2" X 5-1/2" RAIL	71-1/2
4	1-3/4" X 1-3/4" RAIL	71-1/2
5	7/8" X 6" T&G	52-1/4
6	5" HORSE CAP	N/A
8	5/8" U CHANNEL	8-1/4
9	1/2" LATTICE	N/A
10	1/2" FASTENERS	N/A
11	BOTTOM RAIL STIFFENER	71-1/2

ALUMINUM STIFFENER AT BOTTOM RAIL ADDED TO REDUCE DOWNWARD DEFLECTION

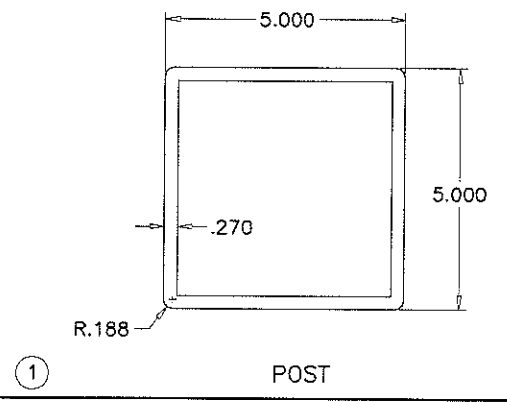
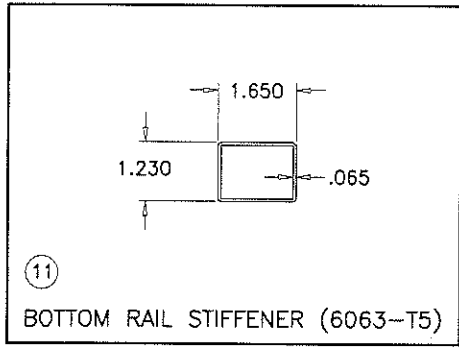
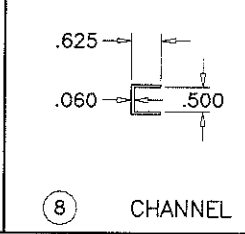
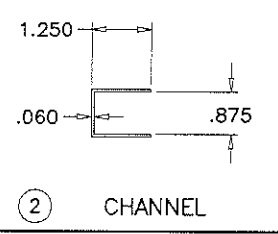
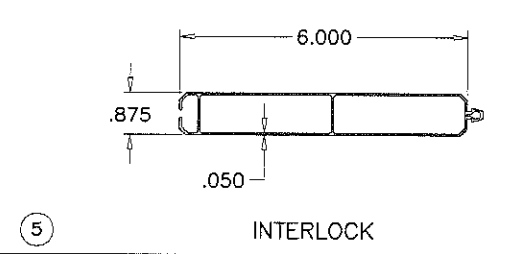
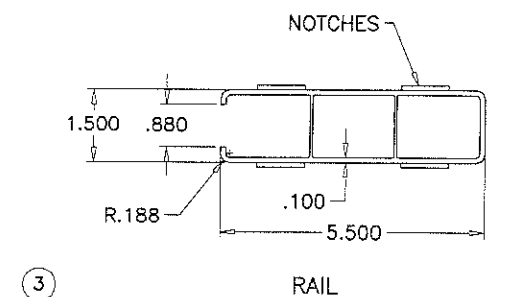
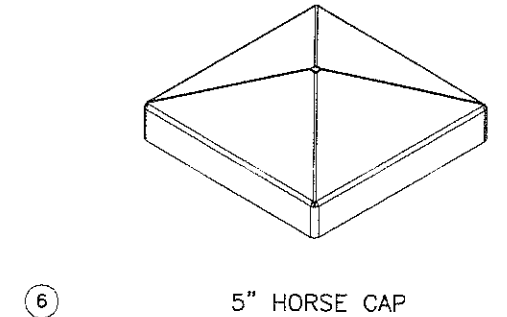
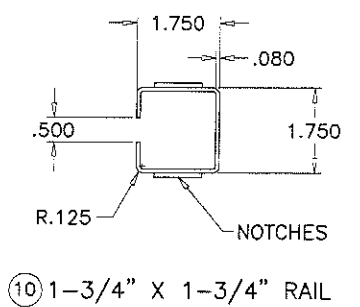
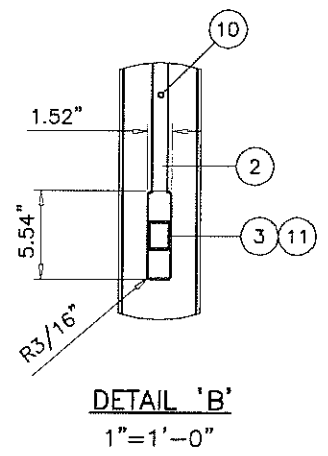
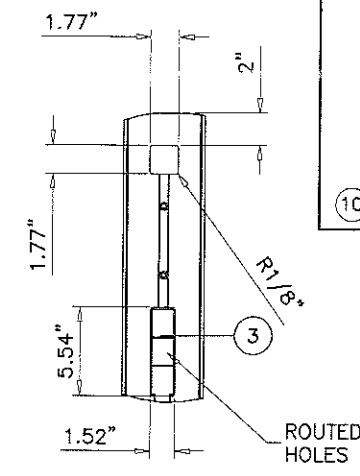

**AL-FAROOQ CORPORATION**  
ENGINEERS & PRODUCT DEVELOPMENT  
1235 S.W. 87 AVE  
MIAMI, FLORIDA 33174  
TEL (305) 264-8100 FAX (305) 262-6978  
FENCES 10-02WBP

PVC PRIVACY FENCE SYSTEMS  
**WESTECH BUILDING PRODUCTS, INC.**  
7451 HIGHWAY 62 EAST  
MOUNT VERNON, INDIANA. 47620  
TEL: (812) 985-3628 FAX: (812) 985-2925

no	date	by	description
A	09.02.10		REV. PER BCCO COMMENTS
B	06.06.12		NO CHANGE THIS SHEET
C	08.18.15		UPDATED TO 2014 FBC

Engr: JAVAD AHMAD  
CIVIL  
FLA. PE # 70592  
C.A.N. 3538  
SEP 30 2011

PRODUCT REVISED  
as complying with the Florida  
Building Code  
Acceptance No 15-1013.08  
Expiration Date 10/06/2020  
By: *[Signature]*  
Miami Dept Product Control

date: 04-09-10  
scale: 1/4" = 1'  
dr. by: HAMID  
chk. by:  
drawing no.  
**10-02**  
sheet 5 of 9



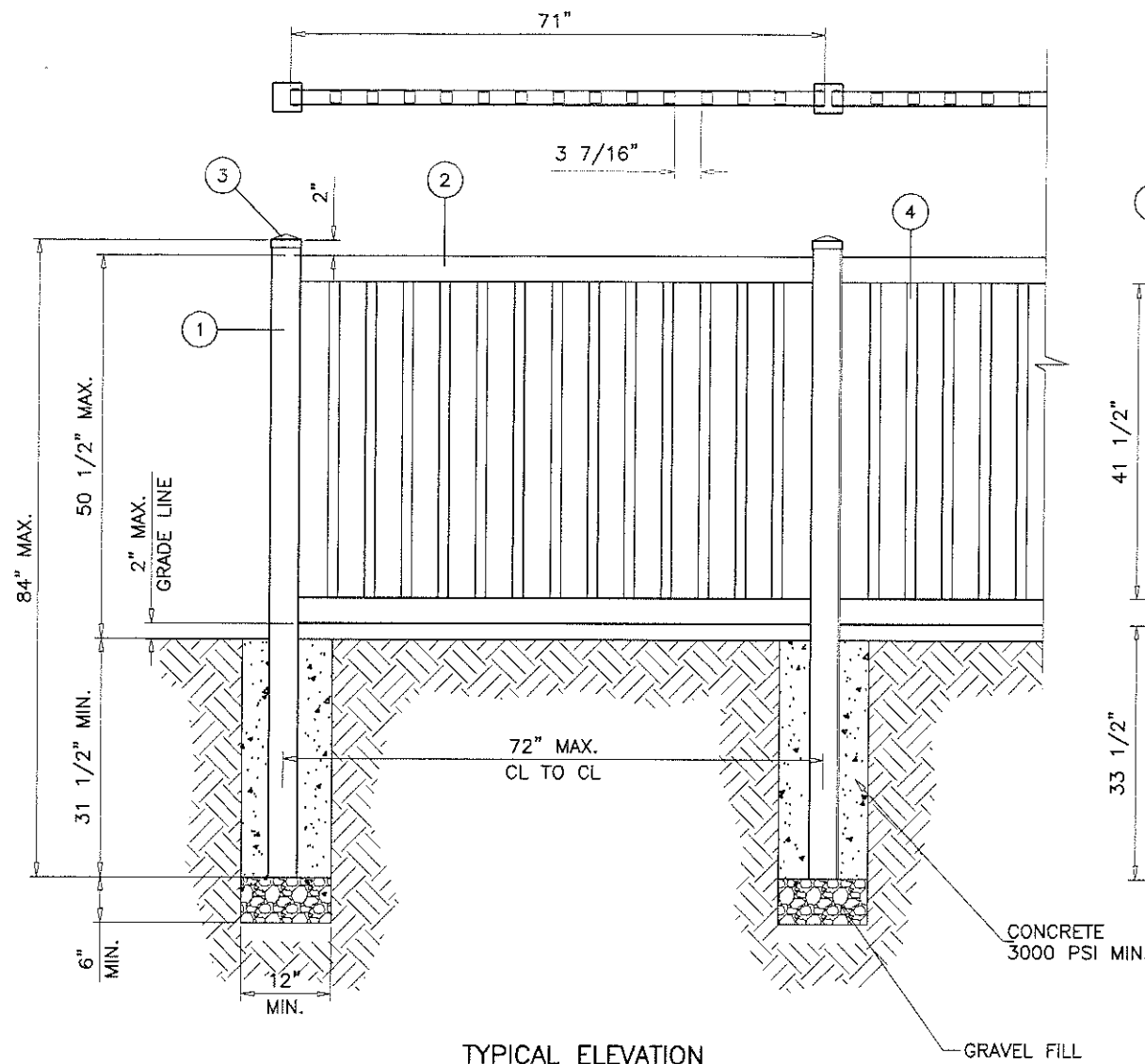

TYPICAL ELEVATION  
1/2" = 1'-0"

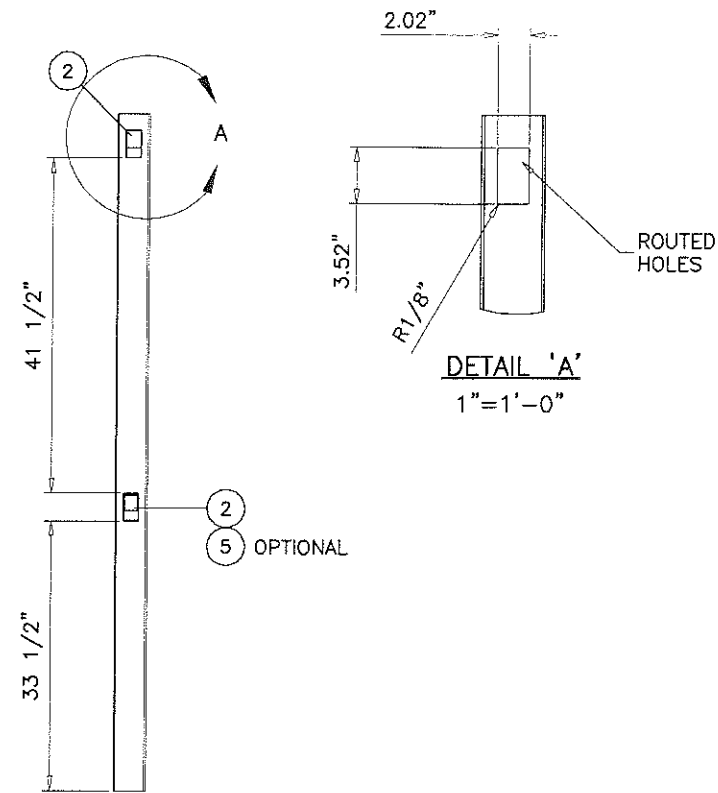

(5) OPTIONAL

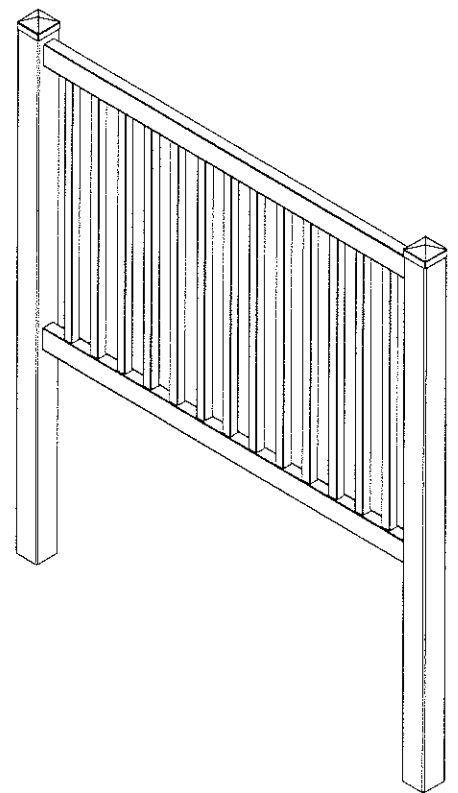

CAPE COD FENCE

ITEM NO.	PART DESCRIPTION	LENGTH IN.
1	4" X 4" POST	84
2	2" X 3-1/2" WEBBED	71
3	4" HORSE CAP	71-1/2
4	1-1/2" X 1-1/2" PICKET	45-1/2
5	BOTTOM RAIL STIFFENER	71

OPTIONAL ALUMINUM STIFFENER AT BOTTOM RAIL  
USE AS REQUIRED

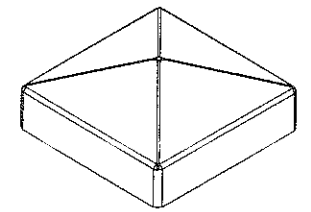

(3) 4" HORSE CAP

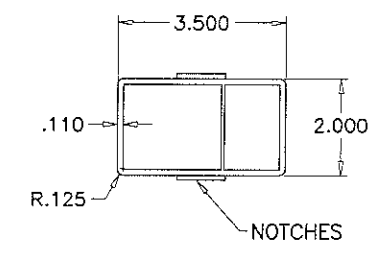

(2) 2" X 3-1/2" WEBBED

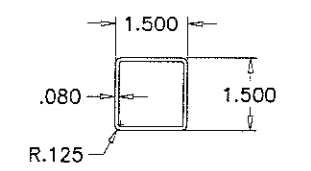

(4) PICKET

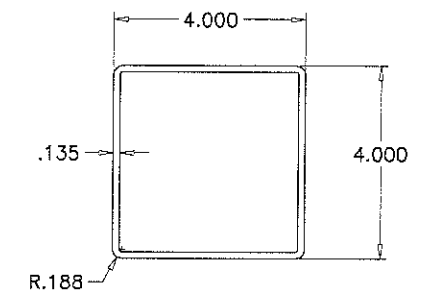

(1) POST

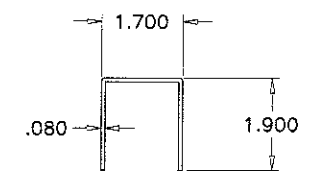

(5) BOTTOM RAIL STIFFENER (6005-T5)

**AL-FAROOQ CORPORATION**  
ENGINEERS & PRODUCT DEVELOPMENT  
1235 S.W. 87 AVE  
MIAMI, FLORIDA 33174  
TEL. (305) 264-8100 FAX. (305) 262-6978  
FENCES\10-02WBIP

PVC PRIVACY FENCE SYSTEMS  
**WESTECH BUILDING PRODUCTS, INC.**  
7451 HIGHWAY 62 EAST  
MOUNT VERNON, INDIANA. 47620  
TEL. (812) 985-3628 FAX. (812) 985-2925

revisions:

no	date	by	description
A	09.02.10		REV. PER BCCO COMMENTS
B	06.06.12		NO CHANGE THIS SHEET
C	08.18.15		UPDATED TO 2014 FBC

Engr: JAVAD AHMAD  
CNIL  
FLA. PE 70592  
C.A.N. 538

*[Signature]*  
SEP 30 2015

PRODUCT REVISED  
as complying with the Florida  
Building Code  
Acceptance No 15-1013.08  
Expiration Date 10/06/2020  
By *[Signature]*  
Miami Dade Product Control

date: 04-09-10  
scale: 1/4" = 1"  
dr. by: HAMID  
chk. by:

drawing no.  
**10-02**

sheet 6 of 9

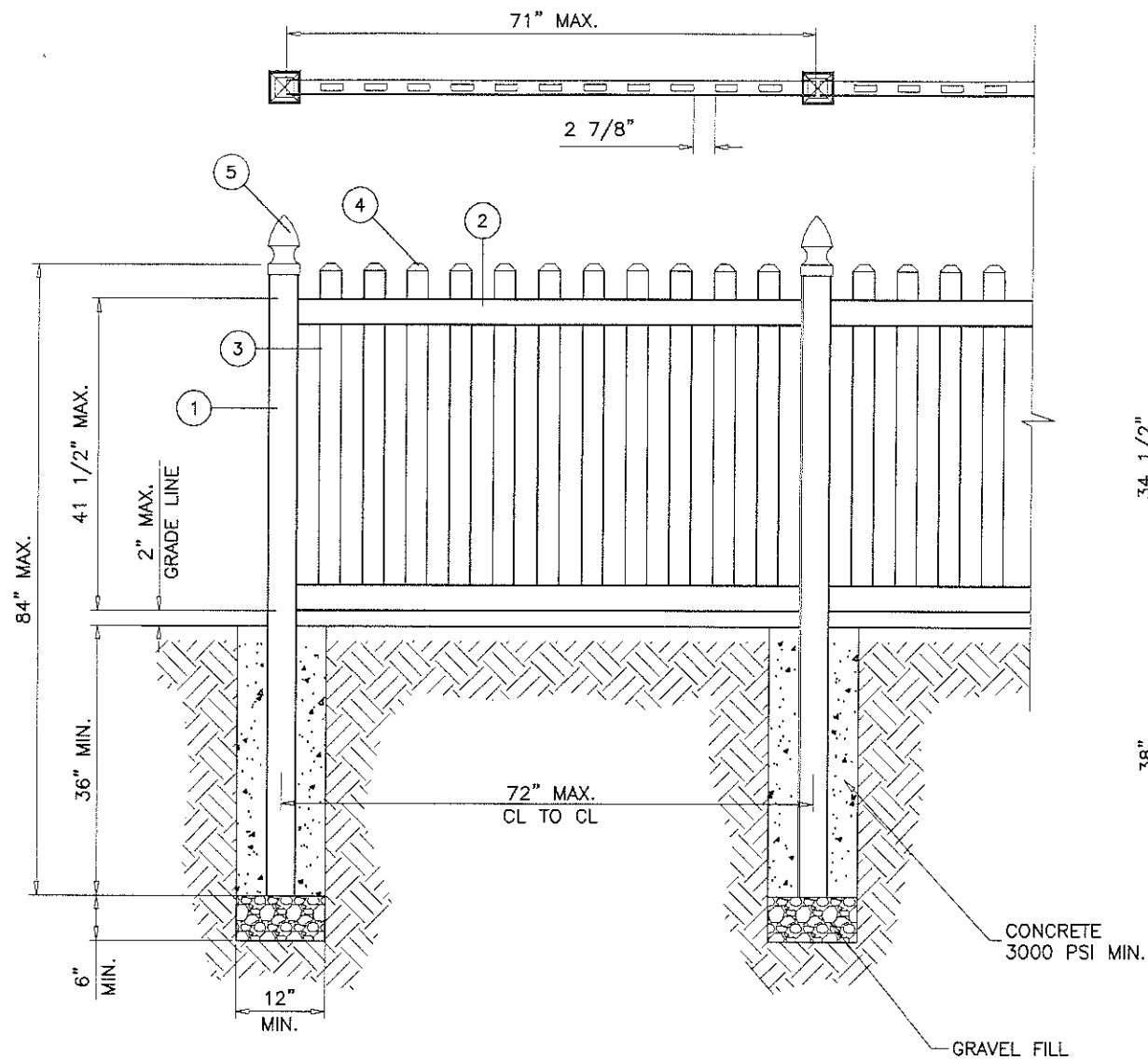

**TYPICAL ELEVATION**  
1/2" = 1'-0"

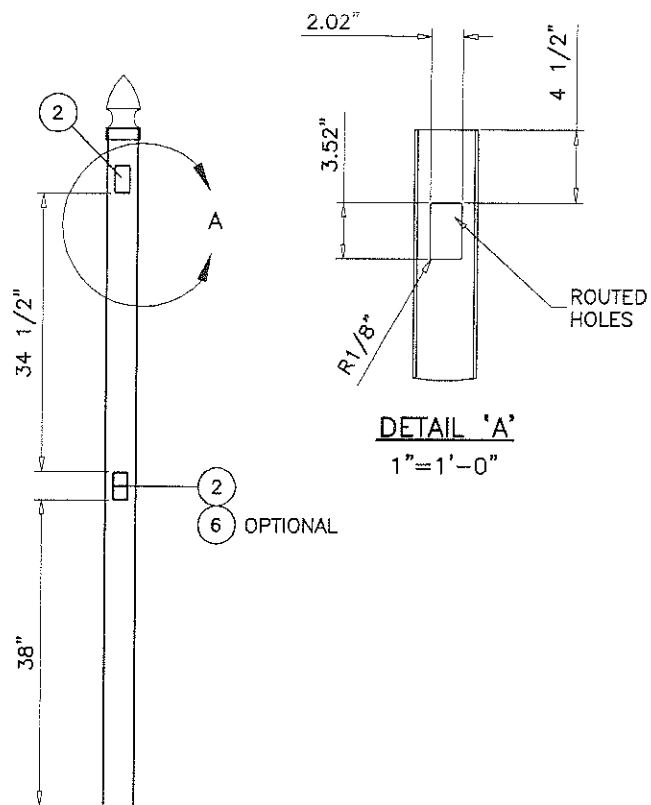

**DETAIL 'A'**  
1" = 1'-0"

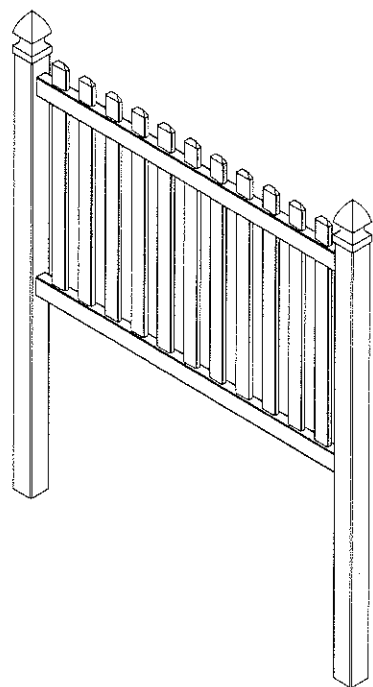

**KEYWEST PICKET FENCE**

ITEM NO.	PART DESCRIPTION	LENGTH IN.
1	4" X 4" POST	84
2	2" X 3-1/2" RAIL	71
3	7/8" X 3" PICKET	45
4	7/8" X 3" CAP	N/A
5	4" GOTHIC CAP	N/A
6	BOTTOM RAIL STIFFENER	71

OPTIONAL ALUMINUM STIFFENER AT BOTTOM RAIL  
USE AS REQUIRED

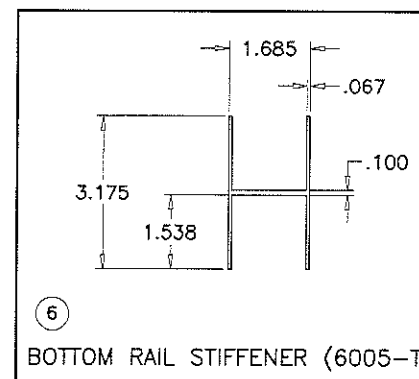

⑥ BOTTOM RAIL STIFFENER (6005-T5)

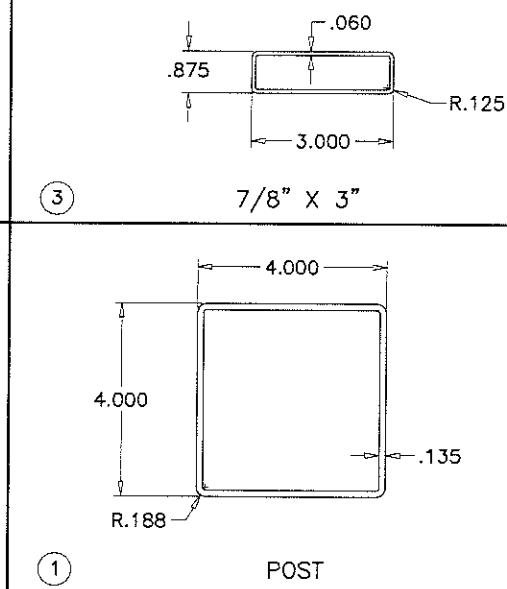

① POST

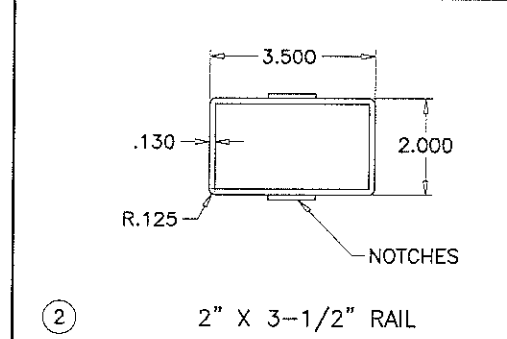

② 2" X 3-1/2" RAIL

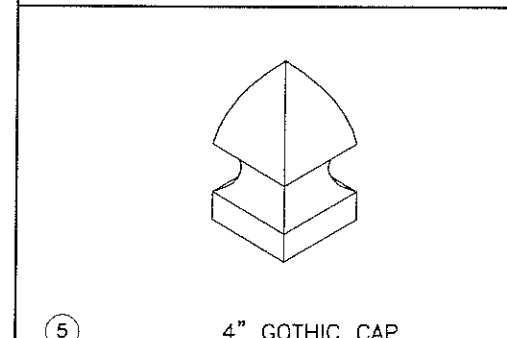

⑤ 4" GOTHIC CAP

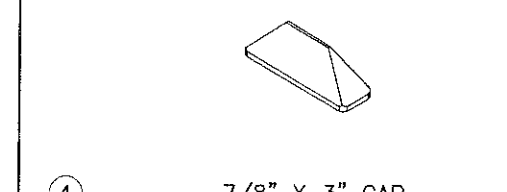

④ 7/8" X 3" CAP

Engr: JAVAD AHMAD  
CIVIL  
FLA. PE # 70592  
C.A.N. 3838

*[Signature]*  
SEP 30 2015

**PRODUCT REVISED**  
as complying with the Florida  
Building Code  
Acceptance No 15-1013.08  
Expiration Date 10/06/2020

By *[Signature]*  
Miami Design Product Control

**AL-FAROOQ CORPORATION**  
ENGINEERS & PRODUCT DEVELOPMENT  
1235 S.W. 87 AVE  
MIAMI, FLORIDA 33174  
TEL. (305) 264-8100 FAX. (305) 262-6978  
FENCES \ 10-02WB

---

**PVC PRIVACY FENCE SYSTEMS**  
**WESTECH BUILDING PRODUCTS, INC.**  
7451 HIGHWAY 62 EAST  
MOUNT VERNON, INDIANA. 47620  
TEL. (812) 985-3628 FAX. (812) 985-2925

---

no	date	by	description
A	09.02.10	REV. PER BCCD COMMENTS	
B	06.06.12	NO CHANGE THIS SHEET	
C	08.18.15	UPDATED TO 2014 FBC	

---

date: 04-09-10  
scale: 1/4" = 1"  
dr. by: HAMID  
chk. by:

---

drawing no.  
**10-02**

---

sheet 7 of 9

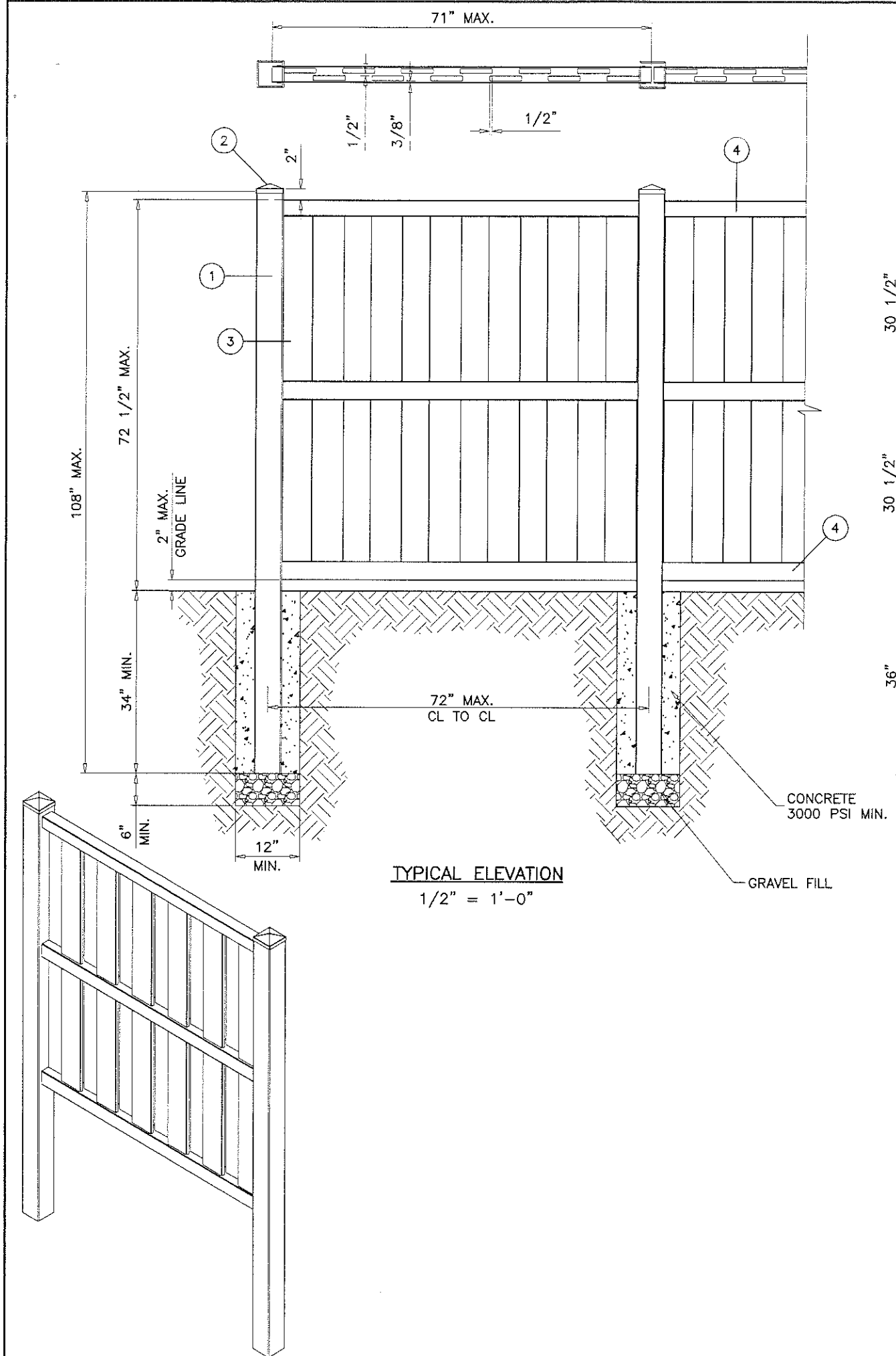

**TYPICAL ELEVATION**  
1/2" = 1'-0"

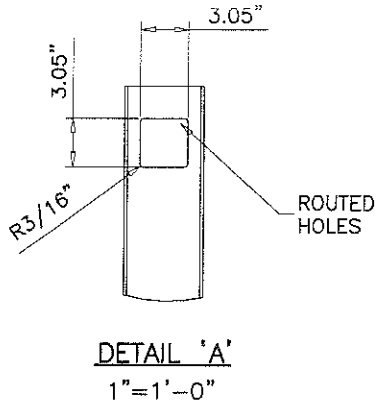
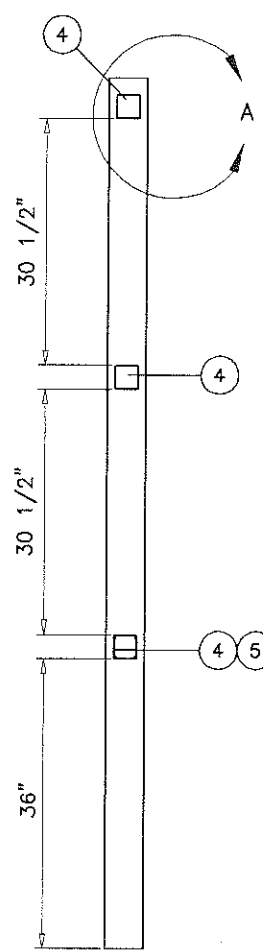

**SHADOW BOX FENCE**

ITEM NO.	PART DESCRIPTION	LENGTH IN.
1	5" X 5" POST	108
2	5" HORSE CAP	N/A
3	7/8" X 6"	69-1/2
4	3" X 3" RAIL	71
5	BOTTOM RAIL STIFFENER	71

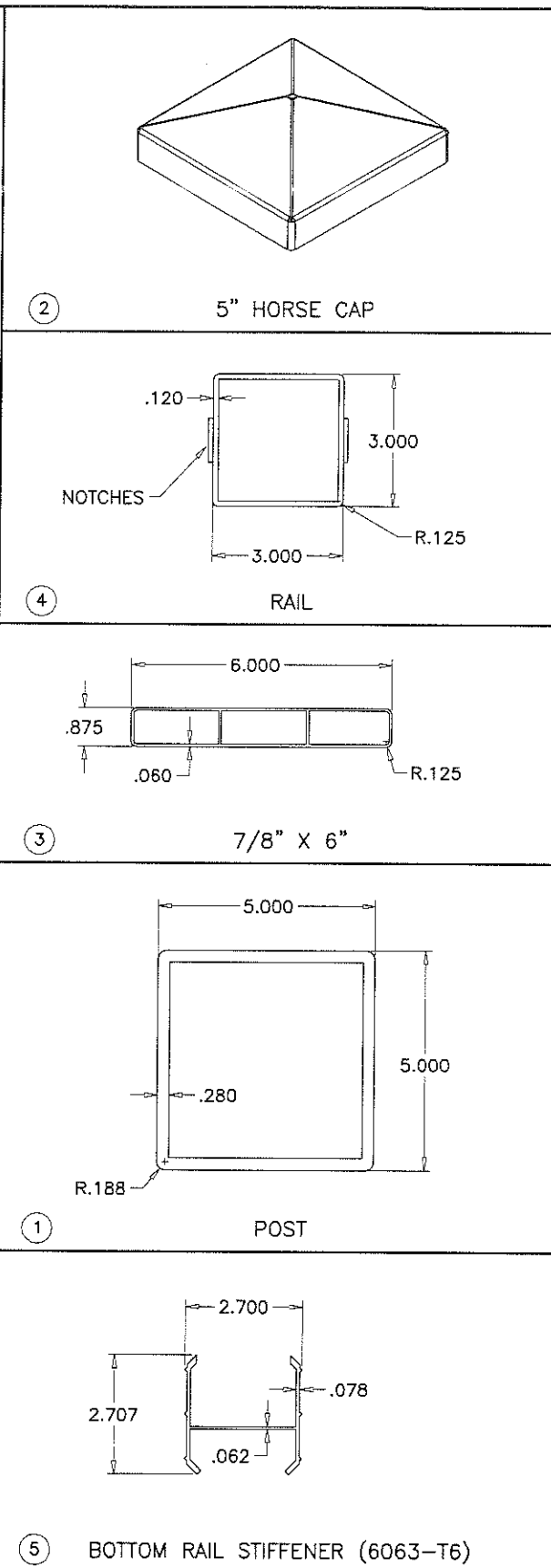

Engr: JAVAD AHMAD  
CML  
FLA. PE # 70592  
C.A.N. 3538

PRODUCT REVISED  
as complying with the Florida  
Building Code  
Acceptance No. 15-1013.08  
Expiration Date 10/06/2020

**AL-FAROOQ CORPORATION**  
ENGINEERS & PRODUCT DEVELOPMENT  
1235 S.W. 87 AVE  
MIAMI, FLORIDA 33174  
TEL (305) 264-8100 FAX (305) 262-6978  
FENCES \ 10-02WBP

**WESTECH BUILDING PRODUCTS, INC.**  
7451 HIGHWAY 62 EAST  
MOUNT VERNON, INDIANA, 47620  
TEL (812) 985-3628 FAX (812) 985-2925

PVC PRIVACY FENCE SYSTEMS

no	date	description
A	09.02.10	REV. PER BCCO COMMENTS
B	06.06.12	NO CHANGE THIS SHEET
C	08.18.15	UPDATED TO 2014 FBC

date: 04-09-10  
scale: 1/4" = 1"  
dr. by: HAMID  
chk. by:

drawing no.  
**10-02**

sheet 8 of 9

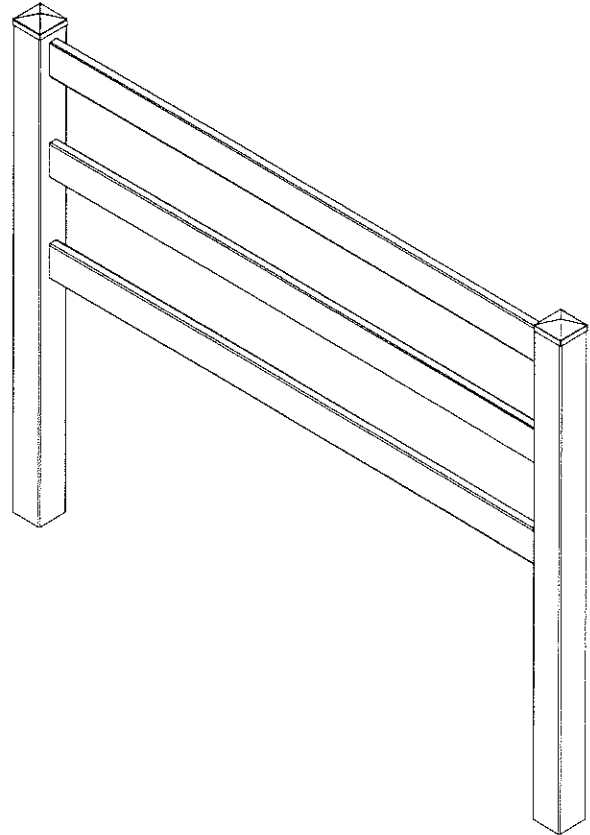
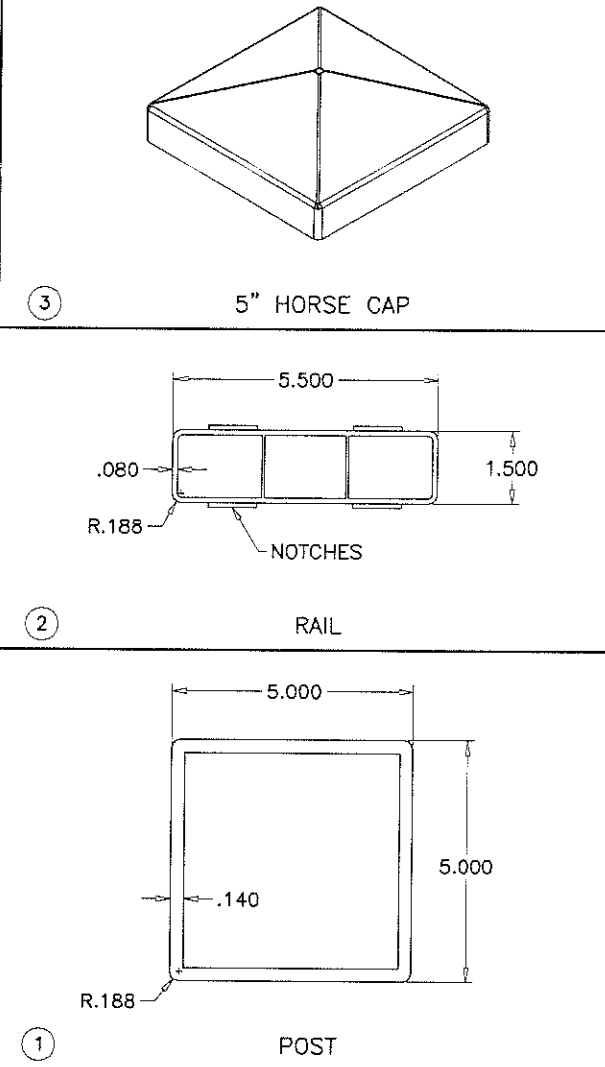
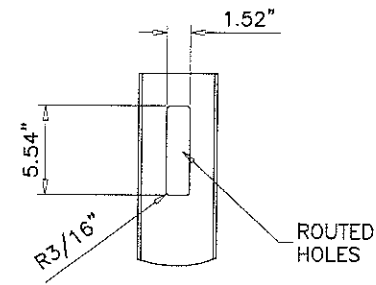
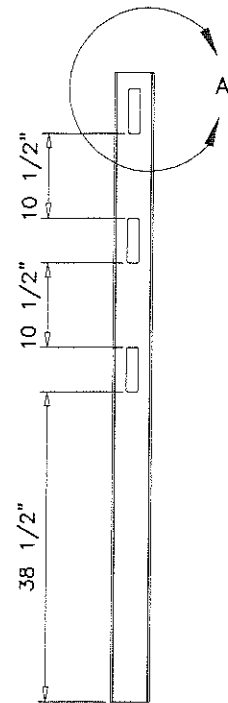
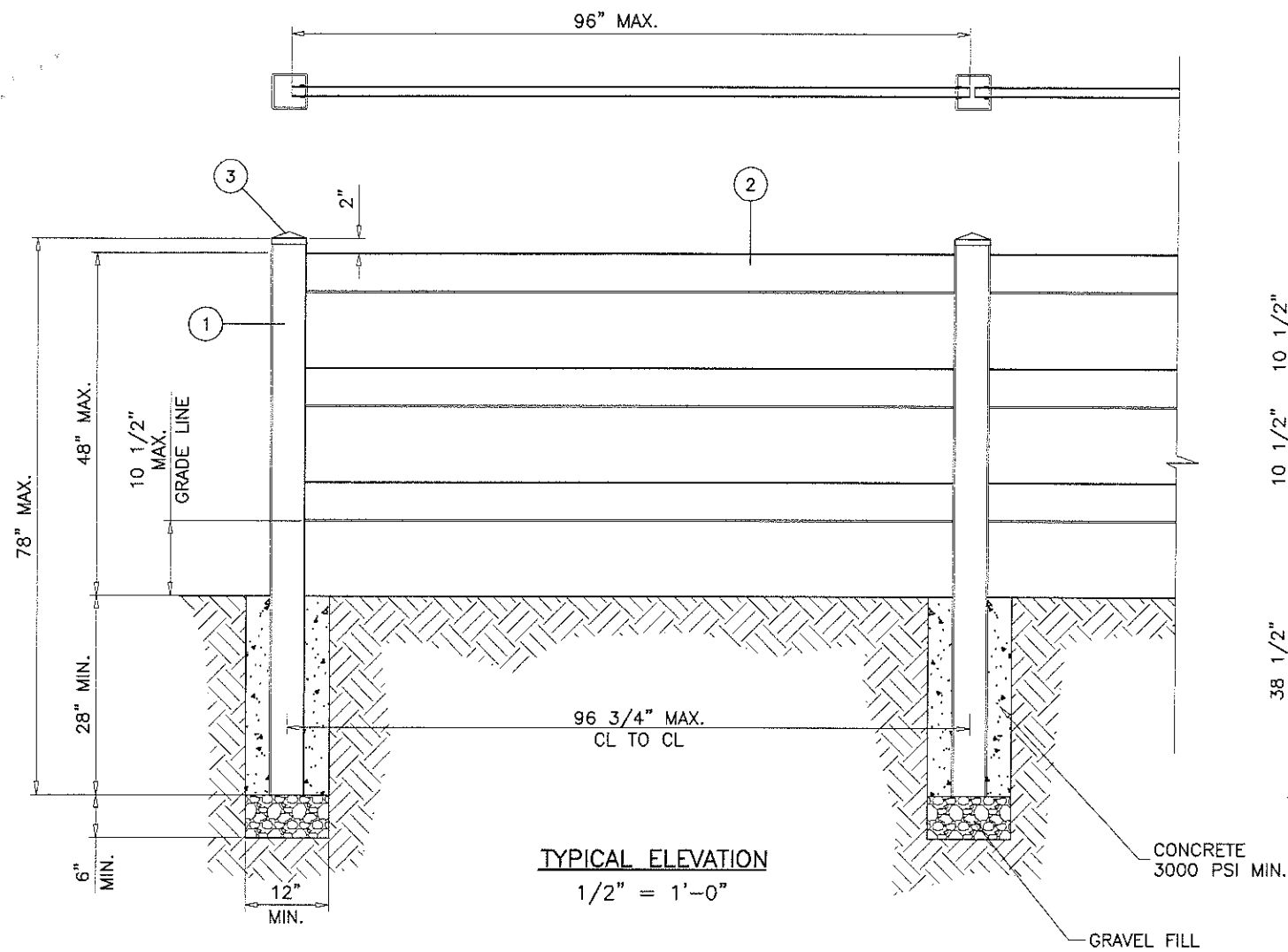

**3 RAIL RANCH FENCE**

ITEM NO.	PART DESCRIPTION	LENGTH IN.
1	5" X 5" POST	78
2	1-1/2" X 5-1/2" RAIL	96
3	5" HORSE CAP	N/A

Engr: JAVAD AHMAD  
CIVIL  
FLA. PE # 70592  
C.A.N. 3538

SEP 30 2019

**PRODUCT REVISED**  
as complying with the Florida  
Building Code  
Acceptance No 15-1013.08  
Expiration Date 10/06/2020

By *[Signature]*  
Miami Design Product Center

**AL-FAROOQ CORPORATION**  
ENGINEERS & PRODUCT DEVELOPMENT  
1235 S.W. 87 AVE  
MIAMI, FLORIDA 33174  
TEL: (305) 264-8100 FAX: (305) 262-8978  
FENCES 10-02WBEP

**WESTECH BUILDING PRODUCTS, INC.**  
7451 HIGHWAY 62 EAST  
MOUNT VERNON, INDIANA. 47620  
TEL: (812) 985-3628 FAX: (812) 985-2925

PVC PRIVACY FENCE SYSTEMS

no	date	by	description
A	09.02.10		REV. PER BCCO COMMENTS
B	06.06.12		NO CHANGE THIS SHEET
C	08.18.15		NO CHANGE THIS SHEET

date: 04-09-10  
scale: 1/4" = 1"  
dr. by: HAMID  
chk. by:

drawing no.  
**10-02**

sheet 9 of 9